

# Stride Industrial Ethernet Switches

## 5-Port Ethernet Switch with Fiber Port - Plastic Case

**STRIDE** SlimLine Industrial Unmanaged Ethernet Switch, plastic case, -10 to +60 °C operating temperature range, four 10/100BaseT RJ45 Ethernet ports and one multimode 100BaseFX ST or SC fiber port. Redundant power inputs with surge and spike protection, auto-crossover, DIN rail mounting. Supports Store and Forward wire speed switching and full-duplex with flow control. UL (cUL) listed and CE certified.



SE-SW5U-ST

SE-SW5U-SC



## Dimensions

Inches [mm]

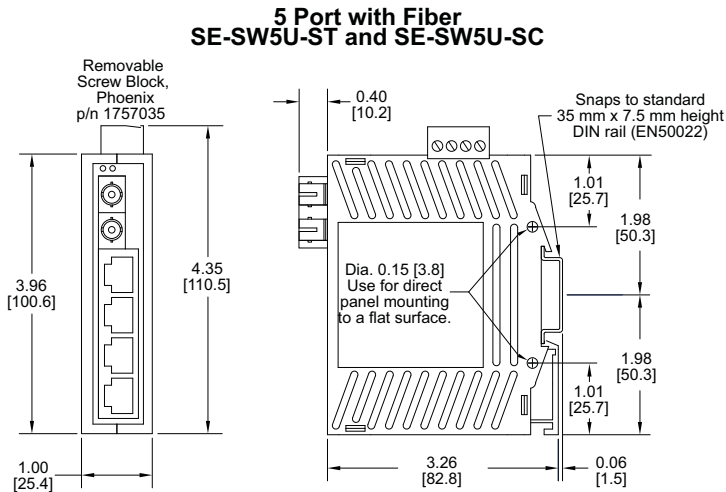

## ACT/LNK LED

This is the **Yellow** LED on models with two LEDs per RJ45 port.

<b>ON (yellow) (not flashing)</b>	Indicates that there is a proper Ethernet connection (Link) between the port and another Ethernet device, but no communications activity is detected.
<b>ON (yellow) (flashing)</b>	Indicates that there is a proper Ethernet connection (Link) between the port and another Ethernet device, and that there is communications activity.
<b>OFF</b>	Indicates that there is not a proper Ethernet connection (Link) between the port and another Ethernet device. Make sure the cable has been plugged securely into the ports at both ends.

## Speed 10/100 LED

This is the **Green** LED on models with two LEDs per RJ45 port.

<b>ON (green)</b>	A 100 Mbps (100BaseT) connection is detected.
<b>OFF</b>	A 10 Mbps (10BaseT) connection is detected.

## Fiber LED

This is the **Green** LED on the fiber optic models.

<b>ON (green) (not flashing)</b>	Indicates that there is a proper fiber connection (Link) between the port and another fiber device, but no communications activity is detected.
<b>ON (green) (flashing)</b>	Indicates that there is a proper fiber connection (Link) between the port and another fiber device, and that there is communications activity.
<b>OFF</b>	Indicates that there is not a proper fiber connection (Link) between the port and another fiber device. Make sure the fiber optic cable has been plugged securely into the ports at both ends.

## Specifications

The following are specifications relevant to the SE-SW5U-ST and SE-SW5U-SC 5-Port Ethernet Switches with Fiber Port.

<b>Input power (typical with all ports active at 100 Mbps)</b>	3.0 W
<b>Weight</b>	4 oz (0.11 kg)
<b>Power connector max. screw torque</b>	5.0 lb-in (0.57 Nm)

# Stride Industrial Ethernet Switches & Media Converters

General Specifications		
<b>Ethernet switch type</b>	Up to 9 ports	
<b>Operating mode</b>	Store and forward wire speed switching, non-blocking	
<b>Devices supported</b>	All IEEE 802.3 compliant devices are supported	
<b>Standards</b>	IEEE 802.3, 802.3u, 802.3x	
<b>MAC addresses</b>	1024 addresses	
<b>Memory bandwidth</b>	3.2 Gbps	
<b>Latency for 10 Mbps ports</b>	16 us + frame time (typical)	
<b>Latency for 100 Mbps ports</b>	5 us + frame time (typical)	
<b>Power input</b>	Redundant Input Terminals	
<b>Input power (typical with all ports active at 100 Mbps)</b>	SE-MC2U-ST SE-MC2U-SC SE-SW5U SE-SW5U-WT	2.0 W
	SE-SW5U-ST SE-SW5U-SC SE-SW5U-ST-WT SE-SW5U-SC-WT	3.0 W
	SE-SW8U SE-SW8U-WT	4.0 W
	SE-SW9U-ST SE-SW9U-SC SE-SW9U-ST-WT SE-SW9U-SC-WT	5.0 W
<b>Input voltage</b>	10-30 VDC (continuous) - Class 2 Power Supply	
<b>Reverse power protection</b>	Yes	
<b>Transient protection</b>	15,000 watts peak	
<b>Spike protection</b>	5,000 watts (10x for 10 us)	
<b>Ethernet isolation</b>	1500 VRMS 1 minute	
<b>Operating temperature range</b>	SE-MC2U-ST SE-MC2U-SC SE-SW5U SE-SW8U SE-SW5U-ST SE-SW5U-SC SE-SW9U-ST SE-SW9U-SC	-10 to +60 °C (+14 to +140 °F), cold startup at -10 °C (+14 °F)
	SE-SW5U-WT SE-SW8U-WT SE-SW5U-ST-WT SE-SW5U-SC-WT SE-SW9U-ST-WT SE-SW9U-SC-WT	-40 to +85 °C (-40 to +185 °F), cold startup at -40 °C (-40 °F)
<b>Storage temperature range</b>	-40 to +85 °C (-40 to +185 °F)	
<b>Humidity (non-condensing)</b>	5 to 95% RH	
<b>Environmental Air</b>	No corrosive gasses permitted	
<b>Vibration, shock &amp; freefall</b>	IEC68-2-6, -27, -32	
<b>Agency Approvals</b>	UL/cUL 508, CSA C22 per EN61010-1, UL/cUL 1604 (Class 1, Div. 2, Groups A, B, C, D), CSA C 22.2/213 9 per EN50021/EN60079-15 (Zone 2, Category 3), CE (ATEX)	
<b>EMI emissions</b>	FCC part 15, ICES-003, EN55022	
<b>EMC immunity</b>	IEC61326-1	
<b>RoHS and WEEE</b>	RoHS (Pb free) and WEEE compliant	
<b>Environmental Air</b>	For use in Pollution Degree 2 environment	

General Specifications Cont'd		
<b>Packaging and protection</b>	SE-MC2U-ST SE-MC2U-SC SE-SW5U SE-SW8U SE-SW5U-ST SE-SW5U-SC SE-SW9U-ST SE-SW9U-SC	UL94V0 Lexan, IP30
	SE-SW5U-WT SE-SW8U-WT SE-SW5U-ST-WT SE-SW5U-SC-WT SE-SW9U-ST-WT SE-SW9U-SC-WT	Aluminum IP30
<b>Dimensions (L x W x H)</b>	See mechanical diagrams for details	

Copper RJ45 Ports: (10/100BaseT)	
<b>10/100BaseT ports</b>	Shielded RJ45
<b>Protocols supported</b>	All standard IEEE 802.3
<b>Ethernet compliancy</b>	IEEE 802.3, 802.3u, 802.3x
<b>Auto-crossover</b>	Yes, allows you to use straight-through or crossover wired cables
<b>Auto-sensing operation</b>	Yes, Full and half duplex
<b>Auto-negotiating</b>	Yes, 10BaseT and 100BaseT
<b>Auto-polarity</b>	Yes, on the TD and RD pair
<b>Flow control</b>	Automatic
<b>Ethernet isolation</b>	1500 VRMS 1 minute
<b>Plug and play</b>	Yes
<b>Cable requirements</b>	Twisted pair (Cat. 5 or better) (shielded recommended)
<b>Max. cable distance</b>	100 meters

Fiber Port: (100BaseFX multimode)	
<b>100BaseFX ports</b>	1
<b>Fiber port mode</b>	Multimode (mm)
<b>Fiber port connector</b>	ST – models SE-XXXX-ST and SE-XXXX-ST-WT SC – models SE-XXXX-SC and SE-XXXX-SC-WT
<b>Optimal fiber cable</b>	50/125 or 62.5/125 μm
<b>Center wavelength</b>	1300 nm
<b>Multimode</b>	Links up to 4 km typ.; 1300 nm; use with 50 or 62.5/125 um fiber > Transmitter power (dB): -21 min, -17 typ, -14 max > Receiver sensitivity (dB): -34 typ, -31 max
<b>Nominal max. distance (full duplex)</b>	4 km
<b>Half and full duplex</b>	Full duplex
<b>Ethernet compliance</b>	100BaseFX
<b>Eye safety (laser)</b>	IEC 60825-1, Class 1; FDA 21 CFR 1040.10 and 1040.11

## Complete documentation

Documentation can be downloaded from  
[www.automationdirect.com](http://www.automationdirect.com).

# Stride™ Industrial Ethernet Switches & Media Converters

## Installation

### DIN Rail Mounting: Plastic Case

DIN rail mounting steps:

1. Hook top back of unit over the DIN rail.
2. Push bottom back onto the DIN rail until it snaps into place.

DIN rail removal steps:

- A. Insert screwdriver into DIN clip and pry until it releases from the DIN rail.
- B. Unhook top of unit from DIN rail.

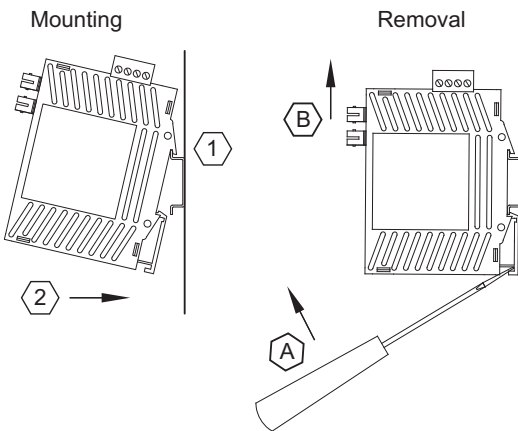

### DIN Rail Mounting: Metal Case

DIN rail mounting steps:

1. Hook top back of unit over the DIN rail.
2. Push bottom back onto the DIN rail until it snaps into place.

DIN rail removal steps:

- A. Push the unit down to free the bottom of the DIN rail.
- B. Rotate the bottom of the unit away from the DIN rail.
- C. Unhook top of unit from DIN rail.

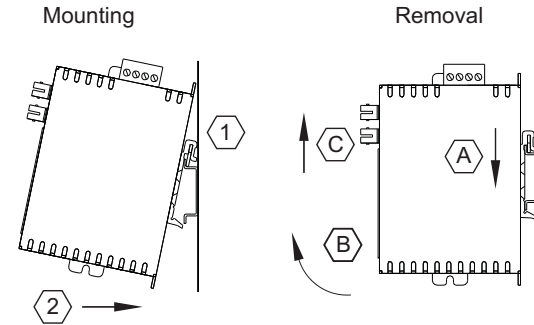

### Optional Mounting



Vertical screw to panel mount.

For better shock and vibration resistance (Metal cased models only)



Flat screw to panel mount.

For a low profile orientation in shallow boxes plus the best shock and vibration resistance.

## Power wiring

### Single DC Power

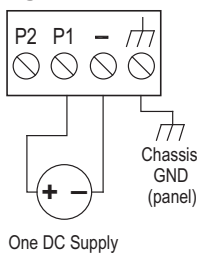

### Redundant DC Power

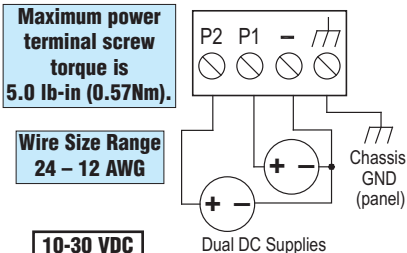

Maximum power terminal screw torque is 5.0 lb-in (0.57Nm).

Wire Size Range 24 – 12 AWG

10-30 VDC

A recommended DC power supply is AutomationDirect.com Part number PSC-24-015.

The power connection terminal block is removable for access to the mounting tab.

## ST or SC Fiber Connector

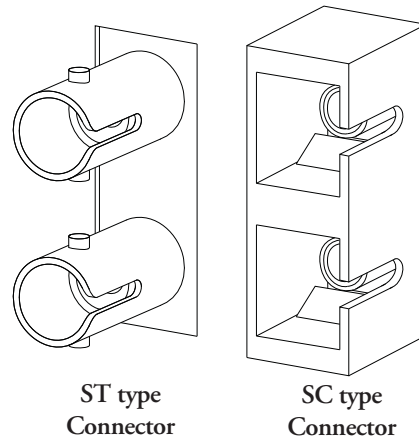

ST type Connector

SC type Connector

# Unmanaged Ethernet Switches and Media Converters

## Performance and Quality

**Plastic Models**

**Starting at \$99**

**Metal Models (-WT)**

**Starting at \$199**



## Industrial Strength Ethernet

Stride is our line of industrial grade unmanaged Ethernet switches and media converters. Designed with our PLC, HMI and drive customers in mind, Stride Ethernet switches are specifically built for industrial environments. With a Stride industrial Ethernet switch on an isolated control LAN, you can reduce data collisions that slow down your network. Stride Ethernet switches automatically determine and remember the devices connected to each port and route messages only through the appropriate ports. Install Stride switches and your Ethernet control network will maintain more consistent cycle times even under heavy I/O and data exchange.

## Extreme Temperatures

For industrial applications where temperatures can change from freezing to sweltering heat, the Stride line offers metal housing models (-WT) that are designed for the most extreme environments, ranging from -40 to +85°C. The metal housing versions also allow you to choose various mounting methods for your application. This is standard and no kits are required!

## Fiber Optic Support

Stride offers models that support ST type Multimode Fiber Optic connections. Fiber optic cables are immune to electrical and magnetic interference. Fiber optics cannot be damaged by induced voltage transients. Fiber optic cabling not only enhances reliability, it saves time you might have spent tracking down those nasty communications problems caused by electrical interference. Also, your network distance is greatly increased when using Fiber optic cabling.

## Features

### Advanced Hardware

- All 10/100 RJ45 ports are auto-detecting, auto-crossover and auto-polarity
- Redundant power inputs with industrial surge and spike protection
- Optional 100Mbps multimode fiber optic port for distances up to 4km

### Real-time Performance

- Store and forward wire speed switching - no delays
- Full-duplex operation with flow control (no collisions!)
- Auto crossover (MDI/MDIX) and auto polarity

### True Industrial Design

- Ethernet Isolation -1500 VRMS 1 minute
- Spike protection - 5,000 watts (10x for 10 uS)
- UL, (cUL) listed and CE certified
- Hazardous locations rated for Class 1, Div. 2

## Simple Installation

With no user setup required, the Stride switches and media converters will immediately start operating as soon as you power them up and connect them to the network.

Company Information

Systems Overview

Programmable Controllers

Field I/O

Software

C-more & other HMI

Drives

Soft Starters

Motors & Gearbox

Steppers/ Servos

Motor Controls

Proximity Sensors

Photo Sensors

Limit Switches

Encoders

Current Sensors

Pressure Sensors

Temperature Sensors

Pushbuttons/ Lights

Process

Relays/ Timers

Comm.

Terminal Blocks & Wiring

Power

Circuit Protection

Enclosures

Tools

Pneumatics

Appendix

Product Index

Part # Index

# Stride™ Industrial Ethernet Switches & Media Converter

## Deterministic Control

The Stride switches automatically determine and remember where each Ethernet device is located and route messages only through the appropriate port. This gives devices on the network an open communications channels and helps minimize network loading. Another benefit is the 10/100 auto-speed selection that enhances the performance of 10 Mbps Ethernet devices by speeding up their message transmissions to 100 Mbps when they are passed to a faster Ethernet backbone.

## Increased Reliability

The Stride Ethernet switches have been designed for the industrial environment. They will survive extreme temperatures, as well as dirty, unreliable industrial power. Meeting UL 1604 (Class I Div. 2), and the IEC68-2 standard for vibration resilience, the Stride switches will provide years of reliable performance in applications too tough for commercial grade switches.



**Mounting Options:** The (-WT) metal housing version allows for various mounting options.

**Power LED** to indicate power on P1 or P2 power inputs

**Fiber Optic Port** on selected models. Multimode fiber optic port with ST type connector that supports half and full duplex with a maximum distance of 4km.

**Activity, Link and Speed LED's** are integrated into the RJ45 ports

**RJ45 Ports** that are fully IEEE 802.3 compliant with 10/100 auto-detecting for speed and duplex (full or half). Auto crossover (MDI/MDIX) automatically supports either straight or crossed cables which greatly reduces cable installation errors.

**True Rugged Design:**  
**>1,000,000 hour MTBF** (mean time between failure) with both Plastic and Metal housing models

**Redundant Power Inputs**  
 Dual power inputs with industrial surge and spike protection to help reduce down time when there is primary power loss. Reverse power protection is also supported.

**Fiber LED** to indicate a proper connection for the ST connectors and network activity

**DIN Rail Mount:**  
 Snaps to standard 35 mm x 7.5 mm height DIN rail (EN50022)

**Industrial Temperature Ranges**  
 Plastic Models:  
 -10 to +60 °C (+14 to +140 °F) operating range temperatures  
 Metal Models (-WT):  
 -40 to +85 °C (-40 to +185 °F) operating range temperatures. 5 to 95% RH humidity range (non-condensing)

**Agency Approvals:**  
 UL1604, CSA C22.2/213 (Class I, Div.2)  
 EN50021/EN60079-15

Model SE-SW5U-ST-WT shown above. For detailed specifications on all models, see following pages