

RHINO PSP24-REM240S Redundancy Module

The PSP24-REM240S redundancy module used with two Rhino PSP Series power supplies creates redundancy to help prevent costly downtime due to power supply failure. The PSP24-REM240S decouples the outputs of the two connected power supplies so that in case of failure, one power supply cannot overload the other.



PSP Redundancy Module						
Part Number		Input Voltage Range	Max Power per Input	Output Voltage	Output Current Max.	Connection
PSP24-REM240S		2 x 5 – 60 VDC	144 W	V in - 0.9 VDC	8 A	Detachable screw terminal block

PSP24-REM240S General Specifications	
Temperature	Operating: -10°C to +70°C max (14°F to +158°F max), Storage: -25°C to +85°C max, (-13°F to +185°F max), Cooling: Natural air convection
Parallel Operation	(2) Rhino PSP power supplies (except PSP24-240S) per module
Electromagnetic Compatibility	In correspondence with connected power supplies
Enclosure Material	Gray plastic, FR2010-110C (UL94 V-0 rated)
Mounting	Built-in snap-on connection for 35mm DIN rail or surface mount adapter included
Indication	Green LED for Output ON
Connections	Plug-in screw terminals, 0.5 to 0.7Nm (4.5 to 6.2lb-in) recommended tightening torque
Wire Size range	24 to 12 AWG (0.21 to 3.16 mm ²)
Dimensions	HxWxD 2.95" x 1.06" x 3.94" (75 x 27 x 100mm)
Agency Approvals	UL/cUL 508 listed, File E197592, CE

Redundancy Module Function Diagram

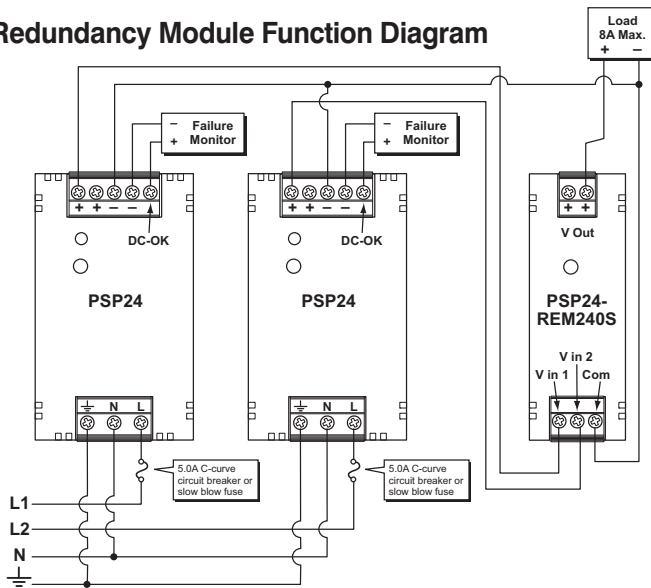

Redundancy Module Connector Positions

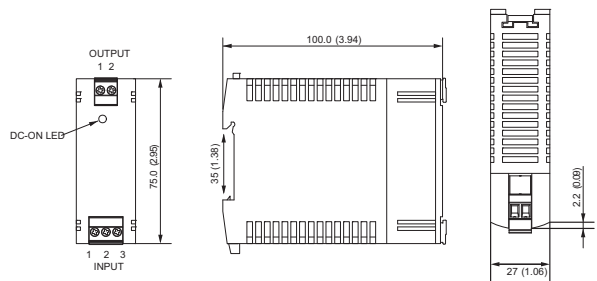

Input	Output
1 +Vin1	1 +Vout
2 +Vin2	2 +Vout
3 Common	

Recommendations for redundant PSP Series power supply applications:

- With no load connected, adjust the output voltage of both power supplies to the same value.
- Use separate input over-current protection for each power supply.
- When possible, connect the input power to each power supply to different phases or circuits.
- Use the DC-OK output and/or DC-ON LED on each power supply to monitor for failure. (PSP05-020S, PSP12-024S and PSP24-024x do not have DC-OK output).
- Connect all output leads together at a single distribution node using leads having the same length and cross section.