

IronHorse Permanent Magnet DC Motors (SCR Rated) Model Overview

IronHorse motors are manufactured by a leading motor supplier with over 20 years experience delivering high-quality motors to the demanding U.S. market. Our supplier produces motors in an ISO9001 facility which tests the motors during production and after final assembly. This is how we can stand behind our IronHorse motors with a **two-year warranty**.

IronHorse DC motors are designed for use on unfiltered SCR (Thyristor) type rectified AC input. They may also be used with PWM (pulse width modulated) type DC adjustable speed drives.

The IronHorse line of DC motors features:

- TENV or TEFC 56C-frame DC motors with rolled steel frames, flange mount and removable mounting bases; 0.33 - 2hp
- Replacement brush sets
- STABLE motor slide bases for adjustable mounting of NEMA motors from 56 - 449T
- Input power of 115 or 230 volts rectified AC can be used with an appropriate SCR drive
- Linear speed/torque characteristics over entire speed range
- High starting torque for heavy load applications
- Capable of dynamic braking for faster stops
- Reversible rotation
- Simple two-lead connection



MTPM-P33-1L18



MTPM-P75-1L18



MTPM-1P5-1M18

IronHorse Part Number Explanation

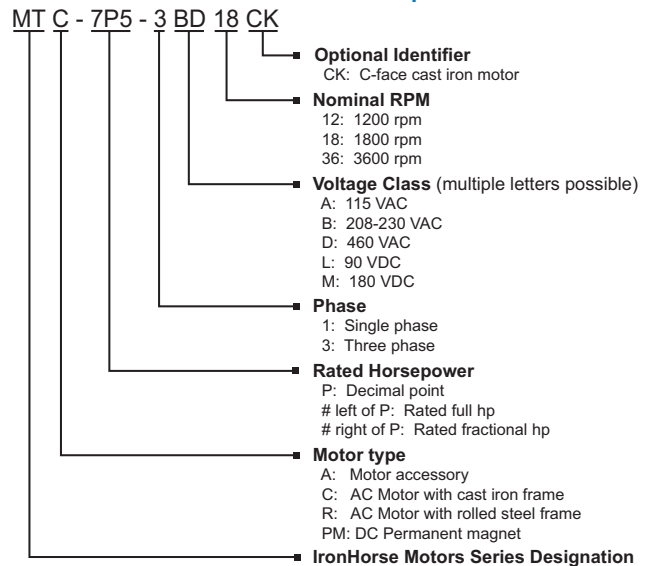

Features

- Available in TENV or TEFC depending on model
- NEMA 56C flange mount
- Rolled steel shell frame / cast aluminum end bell
- Removable base
- Space-saving design
- Large brushes for longer brush life
- Easy access to DC motor brushes (DC motors ship with one set of brushes installed and one set of spare brushes in the box)
- Large easy-to-wire junction box with rubber gasket
- Heavy duty oversized ball bearings
- High tensile strength steel shaft
- Large easy to read nameplate
- Electrically reversible
- Class F winding insulation
- Service Factor: 1.0
- Two year warranty
- cCSA_{US} certified, CE

Applications

- Conveyors
- Turntables
- Where adjustable speed and constant torque are required
- When dynamic braking and reversing capabilities are needed

IronHorse DC Motors

56C Frame TEFC/TENV Motors – DC – 0.33 to 2 hp



Motor Specifications – DC 56C Frame Motors – 1800 RPM										
Part Number	Kw	HP	Base RPM	Armature Voltage	Housing	NEMA Frame	Service Factor	F.L. Amps	Weight (lb)	
MTPM-P33-1L18	0.25	1/3	1800	90 VDC	TENV	56C flange mount	1.0	3.5	17.70	
MTPM-P50-1L18	0.37	1/2								TEFC
MTPM-P75-1L18	0.55	3/4			7.8				25.30	
MTPM-001-1L18	0.75	1								
MTPM-1P5-1L18	1.1	1-1/2			15.4				34.97	
MTPM-P33-1M18	0.25	1/3		180 VDC				TENV		1.75
MTPM-P50-1M18	0.37	1/2			TEFC				2.6	
MTPM-P75-1M18	0.55	3/4						3.9		25.58
MTPM-001-1M18	0.75	1							5.2	
MTPM-1P5-1M18	1.1	1-1/2			7.7			35.70		
MTPM-002-1M18	1.5	2	9.8	61.95						

Note: Please review the AutomationDirect Terms & Conditions for warranty and service on this product.

Performance Data – DC 56C Frame Motors – 1800 RPM																												
Part Number	HP	Armature Voltage	Torque (lb-ft)	*Form Factor	Ambient Temp.	Insulation Class	Ball Bearings		Mounting	Wire / Housing	Shaft	Constant Torque Speed Range	Overall Speed Range	Base / Type	Paint Color	Efficiency (%)												
			Full Load				DE Bearing	ODE Bearing																				
MTPM-P33-1L18	1/3	90 VDC	0.97	1.35	40°C (104°F)	F	6203	6203	Top Mounted	Junction Box	Keyed	90-1800 RPM	0-2000 RPM	Rigid Removable	Gray	79												
MTPM-P50-1L18	1/2		1.46													80												
MTPM-P75-1L18	3/4		2.19																									
MTPM-001-1L18	1		2.92																									
MTPM-1P5-1L18	1-1/2		4.38																									
MTPM-P33-1M18	1/3	180 VDC	0.97													1.35	40°C (104°F)	F	6203	6203	Top Mounted	Junction Box	Keyed	90-1800 RPM	0-2000 RPM	Rigid Removable	Gray	79
MTPM-P50-1M18	1/2		1.46																									80
MTPM-P75-1M18	3/4		2.19																									
MTPM-001-1M18	1		2.92																									
MTPM-1P5-1M18	1-1/2		4.38																									
MTPM-002-1M18	2	5.84	85																									

* See Additional information in form factor table

Form Factor

The voltage used to power a permanent magnet (PM) DC motor is not pure DC. It is derived by rectifying a supplied AC voltage. The resulting DC voltage has a ripple that is related to the frequency of the AC input.

Form factor is the ratio of Irms to Idc and indicates how close the driving voltage is to pure DC. The form factor for a DC battery is 1.0. The higher the form factor is above 1.0, the more it deviates from pure DC. The Form Factor Table shows examples of commonly used voltages.

Form factor should not exceed 1.35 for continuous operation. Half wave rectification is not recommended as it drastically increases form factor.

Operating Ironhorse PMDC motors with DC voltages with form factors higher than 1.35 can result in premature brush failure and excessive motor heating.

Form Factor Table	
Form factor	DC voltage source
1.0	Battery (pure DC)
1.05	Pulse width modulation (PWM)
1.35	Full wave rectification (single phase)*
1.9	Half wave rectification (single phase)**

* Most Common DC Drive for Applications .33 - 2HP

** Not Recommended

IronHorse DC Motors

56C Frame TENV DC Motors - .33 to .5 hp - Dimensions

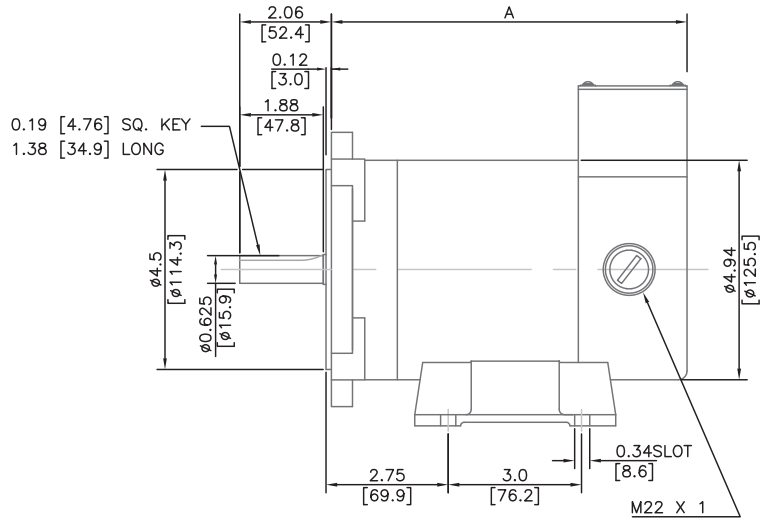
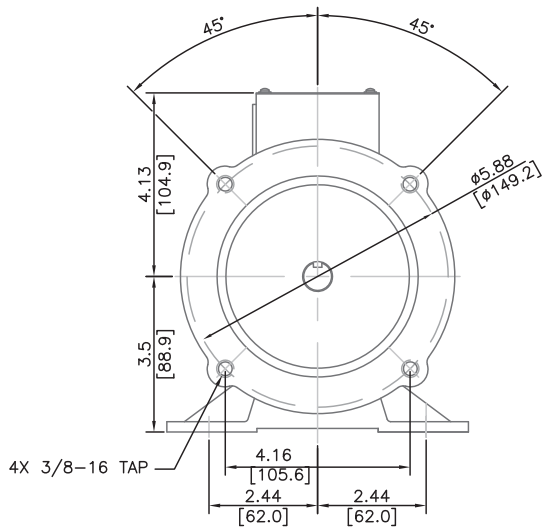

A = 8.0"	[203.2]	- 0.33 HP, 90VDC, 1800RPM
A = 8.0"	[203.2]	- 0.33 HP, 180VDC, 1800RPM
A = 8.88"	[225.5]	- 0.50 HP, 90VDC, 1800RPM
A = 8.88"	[225.5]	- 0.50 HP, 180VDC, 1800RPM

UNITS: INCHES [mm]

56C Frame TEFC DC Motors - .75 to 1.5 hp - Dimensions

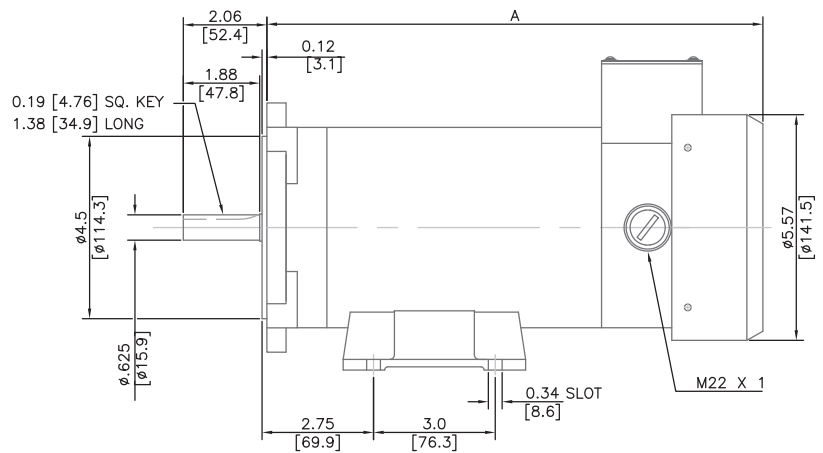
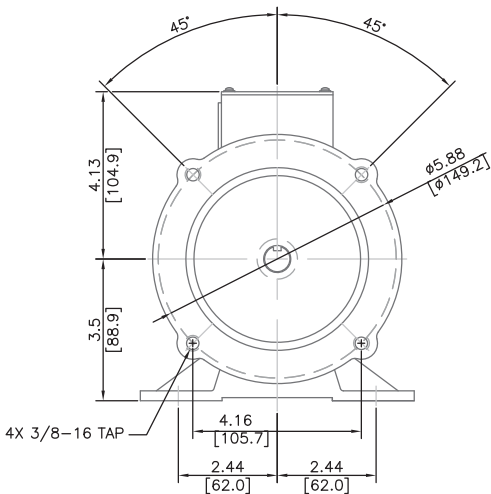

A = 11.45"	[290.8]	- .75 HP, 90VDC, 1800RPM
A = 11.45"	[290.8]	- .75 HP, 180VDC, 1800RPM
A = 12.24"	[311.0]	- 1 HP, 90VDC, 1800RPM
A = 12.24"	[311.0]	- 1 HP, 180VDC, 1800RPM
A = 14.39"	[365.5]	- 1.5 HP, 90VDC, 1800RPM
A = 14.39"	[365.5]	- 1.5 HP, 180VDC, 1800RPM

UNITS: INCHES [mm]

