

GS/DURAPULSE Accessories – Software



Overview

GSoft, the configuration software for the GS/DURAPULSE drives, allows a personal computer to be directly connected to the drives via RS-232 or RS-485 (RS-485 requires FA-ISOCAN or user supplied converter). You can perform a variety of functions to allow easy, intuitive, and secure set-up of any application that is required using GSoft.

System Requirements

To run GSoft, your PC must meet the following requirements:

- Windows 95, 98, Me, NT, 2000 or XP
- Internet Explorer 4.0 or higher (for HTML help support)
- 24 Mb of available memory
- 8Mb hard drive space
- Available RS-232 serial port

Features

- Create new drive configurations using one of three views:
 - Quick Start - Allows for just the basic set-up to get quick and simple applications up and running ASAP.
 - Detailed - The complete set-up of all parameters in the drive.
 - Schematic Views - Set up the drive using the interactive schematic view. Create a printable cad-like drawing at the same time for future documentation and maintenance-friendly activities.
- Upload/download drive configurations.
- Edit drive configuration .
- Archive/store multiple drive configurations on your PC .
- Trend drive operation parameters in real time.
- Maintenance keypad will allow the user to commission the drive from the PC, check rotation, and run a basic cycle.
- Live PID tuning with active tuning control. Take the difficulty out of PID tuning with a real time trend.
- View drive faults.
- OPC client with KEPDirect EBC I/O server over the Ethernet with the GS-EDRV option card
- Have a large system with KEPDirect already being used to supply information to your SCADA system? Now program online with drive changes.

GS/DURAPULSE AC Drive Software	
Part Number	Description
GSOFT	configuration software
GS-232CBL	RS-232 cable
FA-ISOCAN	RS-232 to RS-422/485 converter with ANTE

Can be used with all series GS/DURAPULSE drives; FA-ISOCAN required for GS1 and DURAPULSE drives.

GSoft offers three software configuration methods

Detailed Configuration

The Detailed Configuration method provides AC drive parameter access in a tabbed dialog format. Detailed Configuration can be used for new or existing configurations.

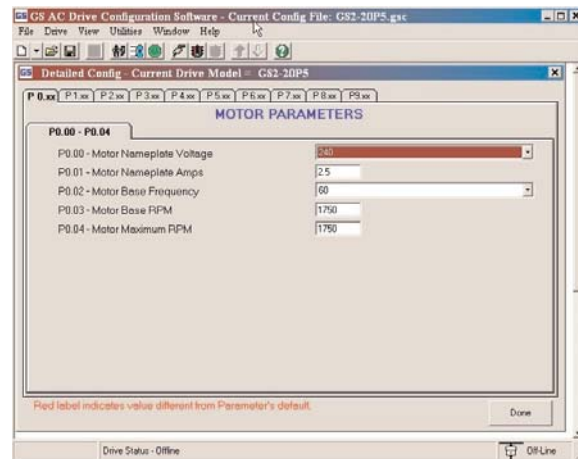

Schematic View Configuration

The Schematic View Configuration method uses a schematic picture of the AC drive and external connections to guide you through the setup of the AC drive. The Schematic View method can be used for new or existing configurations.

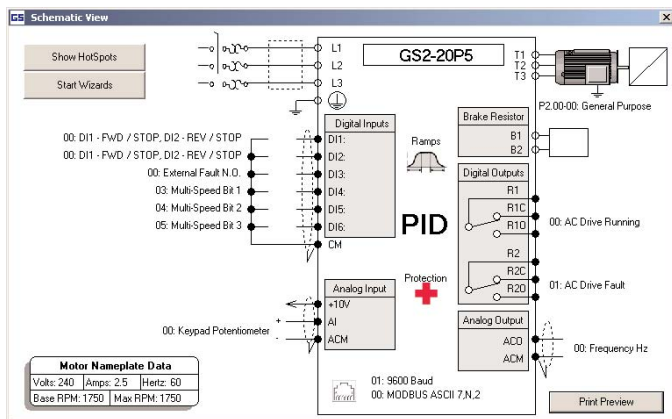

Quick Start Configuration

The Quick Start Configuration method guides you through the most commonly used AC drive parameters. Quick Start Configuration may ONLY be used to create a new configuration. Once created and saved, subsequent editing is done using the Detailed or Schematic View methods.

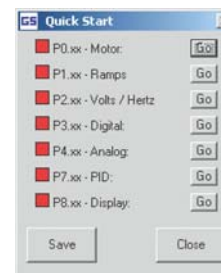

PLC Overview

DL05/06 PLC

DL105 PLC

DL205 PLC

DL305 PLC

DL405 PLC

Field I/O

Software

C-more HMIs

Other HMI

AC Drives

Motors

Steppers/Servos

Motor Controls

Proximity Sensors

Photo Sensors

Limit Switches

Encoders

Pushbuttons/Lights

Process

Relays/Timers

Comm.

TB's & Wiring

Power

Enclosures

Appendix

Part Index