

# GS/DURAPULSE Accessories – Overview

## Accessories part numbering system

**Note:** With the exception of the EMI filters and RF filters, each accessory part number begins with GS, followed by the AC Drive rating, and then the relevant accessory code. Following the accessory code, you will find a description code when applicable. The diagram at right shows the accessory part numbering system.

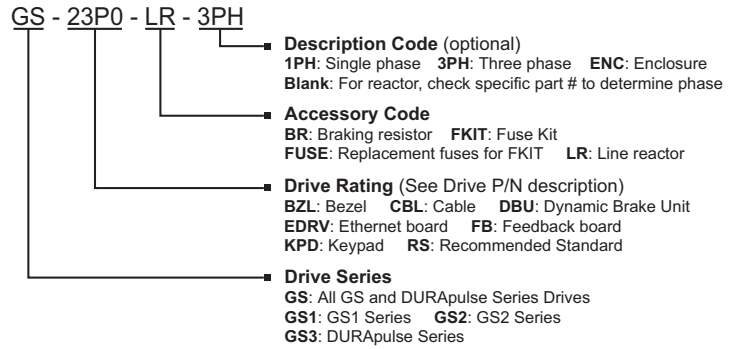

### Under 20hp

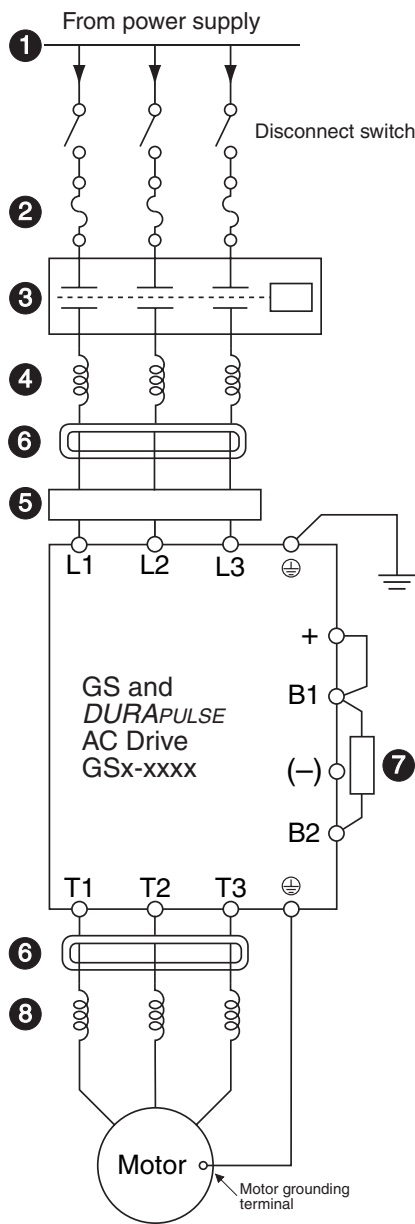

## 1 Power Supply

Please follow the specific power supply requirements shown in Chapter 1 and the Warning section of the applicable GS or *DURAPULSE* AC Drives User Manual.

## 2 Fuses (Refer to page 12–68.)

Input fuses protect the AC drive from excessive input current due to line surges, short circuits, and ground faults. They are recommended for all installations and may be required for UL-listed installations. (*AutomationDirect fuses are not available for GS1 drives.*)

## 3 Contactor (Optional) (Refer to the Motor Controls section.)

Do not use a contactor or disconnect switch for run/stop control of the AC drive and motor. This will reduce the operating life cycle of the AC drive. Cycling a power circuit switching device while the AC drive is in run mode should be done only in emergency situations.

## 4 Input Line Reactor (Optional) (Refer to page 12–50.)

Input line reactors protect the AC drive from transient overvoltage conditions, typically caused by utility capacitor switching. The input line reactor also reduces the harmonics associated with AC drives. Input line reactors are recommended for all installations.

## 5 EMI filter (Optional) (Refer to page 12–61.)

Input EMI filters reduce electromagnetic interference or noise on the input side of the AC drive. They are required for CE compliance and recommended for installations prone to or sensitive to electromagnetic interference. (*Separate EMI filters are not necessary for GS1 drives.*)

## 6 RF filter (Optional) (Refer to page 12–67.)

RF filters reduce the radio frequency interference or noise on the input or output side of the inverter.

## 7 Braking Resistor (Optional) (Refer to page 12–56.)

Dynamic braking allows the AC drive to produce additional braking (stopping) torque. AC drives can typically produce between 15% & 20% braking torque without the addition of any external components. The addition of optional braking may be required for applications that require rapid deceleration or high inertia loads. (*Braking resistors are not available for GS1 drives.*)

## 8 Output Line Reactor (Optional) (Refer to page 12–50.)

Output line reactors protect the motor insulation against AC drive short circuits and IGBT reflective wave damage, and also “smooth” the motor current waveform, allowing the motor to run cooler. They are **recommended for operating “non-inverter-duty” motors** and when the **length of wiring between the AC drive and motor exceeds 75 feet.**

# GS/DURAPULSE Accessories – Overview

## 20hp & Over (DURAPULSE only)

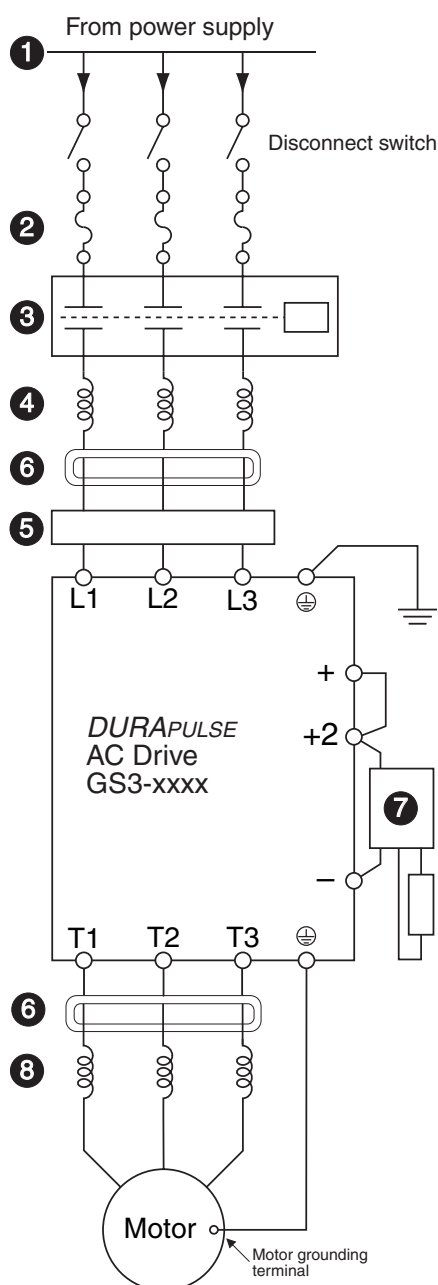

### 1 Power Supply

Please follow the power supply requirements shown in Chapter 1 of the *DURAPULSE AC Drives User Manual*.

### 2 Fuses (Refer to page 12–68.)

Input fuses protect the AC drive from excessive input current due to line surges, short circuits, and ground faults. They are recommended for all installations and may be required for UL-listed installations.

### 3 Contactor (Optional) (Refer to the Motor Controls section.)

Do not use a contactor or disconnect switch for run/stop control of the AC drive and motor. This will reduce the operating life cycle of the AC drive. Cycling a power circuit switching device while the AC drive is in run mode should be done only in emergency situations.

### 4 Input Line Reactor (Optional) (Refer to page 12–50.)

Input line reactors protect the AC drive from transient overvoltage conditions, typically caused by utility capacitor switching. The input line reactor also reduces the harmonics associated with AC drives. Input line reactors are recommended for all installations.

### 5 EMI filter (Optional) (Refer to page 12–61.)

Input EMI filters reduce electromagnetic interference or noise on the input side of the AC drive. They are required for CE compliance and recommended for installations prone to or sensitive to electromagnetic interference.

### 6 RF filter (Optional) (Refer to page 12–67.)

RF filters reduce the radio frequency interference or noise on the input or output side of the inverter.

### 7 Braking Unit & Braking Resistor (Optional) (pg 12–54)

Dynamic braking allows the AC drive to produce additional braking (stopping) torque. AC drives can typically produce between 15% & 20% braking torque without the addition of any external components. The addition of optional braking may be required for applications that require rapid deceleration or high inertia loads.

### 8 Output Line Reactor (Optional) (Refer to page 12–50.)

Output line reactors protect the motor insulation against AC drive short circuits and IGBT reflective wave damage, and also “smooth” the motor current waveform, allowing the motor to run cooler. They are **recommended for operating “non-inverter-duty” motors** and when the **length of wiring between the AC drive and motor exceeds 75 feet**.

PLC Overview

DL05/06 PLC

DL105 PLC

DL205 PLC

DL305 PLC

DL405 PLC

Field I/O

Software

C-more HMIs

Other HMI

AC Drives

Motors

Steppers/Servos

Motor Controls

Proximity Sensors

Photo Sensors

Limit Switches

Encoders

Pushbuttons/Lights

Process

Relays/Timers

Comm.

TB's &amp; Wiring

Power

Enclosures

Appendix

Part Index

# GS/DURAPULSE Drives Accessories – Line Reactors

115 Volt Single Phase Input Reactors							
<i>NOTE: Single phase line reactors should not be installed on the output of the AC Drive.</i>							
Part Number		Rated Amps	Impedance	Inductance	Watt Loss	Drive Model and Side / Phase / Volts	Drive hp
<b>GS-10P2-LR</b>		18	3%	0.80 mH	19	GS1-10P2 (input) / 1ph / 115V GS2-10P2 (input) / 1ph / 115V	0.25
<b>GS-10P5-LR</b>		25	3%	0.50 mH	23	GS1-10P5 (input) / 1ph / 115V GS2-10P5 (input) / 1ph / 115V	0.5
<b>GS-11P0-LR</b>		35	3%	0.40 mH	36	GS2-11P0 (input) / 1ph / 115V	1

230 Volt Single Phase Input Reactors							
<i>NOTE: Single phase line reactors should not be installed on the output of the AC Drive.</i>							
Part Number		Rated Amps	Impedance	Inductance	Watt Loss	Drive Model and Side / Phase / Volts	Drive hp
<b>GS-20P5-LR-1PH</b>		8	3%	6.50 mH	13	GS1-20P5 (input) / 1ph / 230V GS2-20P5 (input) / 1ph / 230V	0.5
<b>GS-21P0-LR-1PH</b>		12	3%	6.50 mH	13	GS1-21P0 (input) / 1ph / 230V GS2-21P0 (input) / 1ph / 230V	1
<b>GS-22P0-LR-1PH</b>		18	3%	3.00 mH	25	GS2-22P0 (input) / 1ph / 230V	2
<b>GS-23P0-LR-1PH</b>		35	3%	2.50 mH	26	GS2-23P0 (input) / 1ph / 230V	3

230 Volt Three Phase Input / Output Reactors							
Part Number		Rated Amps	Impedance	Inductance	Watt Loss	Drive Model and Side / Phase / Volts	Drive hp
<b>GS-20P5-LR-3PH</b>		4	3%	6.50 mH	13	GS1-10P5 (output) / 3ph / 230V GS1-20P5 (in/out) / 3ph / 230V GS2-20P5 (in/out) / 3ph / 230V	0.5
<b>GS-21P0-LR-3PH</b>		4	3%	3.00 mH	7	GS1-21P0 (in/out) / 3ph / 230V GS2-21P0 (in/out) / 3ph / 230V GS3-21P0 (in/out) / 3ph / 230V	1
<b>GS-22P0-LR-3PH</b>		8	3%	1.50mH	11	GS1-22P0 (in/out) / 3ph / 230V GS2-22P0 (in/out) / 3ph / 230V GS3-22P0 (in/out) / 3ph / 230V	2
<b>GS-23P0-LR-3PH</b>		12	3%	1.30mH	23	GS2-23P0 (in/out) / 3ph / 230V GS3-23P0 (in/out) / 3ph / 230V	3
<b>GS-25P0-LR</b>		18	3%	0.80mH	19	GS2-25P0 (in/out) / 3ph / 230V GS3-25P0 (in/out) / 3ph / 230V	5
<b>GS-27P5-LR</b>		25	3%	0.50mH	23	GS2-27P5 (in/out) / 3ph / 230V GS3-27P5 (in/out) / 3ph / 230V	7.5
<b>GS-2010-LR</b>		35	3%	0.40mH	36	GS3-2010 (in/out) / 3ph / 230V	10
<b>GS-2015-LR</b>		45	3%	0.30mH	33	GS3-2015 (in/out) / 3ph / 230V	15
<b>GS-2020-LR</b>		55	3%	0.25mH	39	GS3-2020 (in/out) / 3ph / 230V	20
<b>GS-2025-LR</b>		80	3%	0.20mH	88	GS3-2025 (in/out) / 3ph / 230V	25
<b>GS-2030-LR</b>		80	3%	0.20mH	88	GS3-2030 (in/out) / 3ph / 230V	30
<b>GS-2040-LR</b>		130	3%	0.10mH	95	GS3-2040 (in/out) / 3ph / 230V	40
<b>GS-2050-LR</b>		130	3%	0.10mH	95	GS3-2050 (in/out) / 3ph / 230V	50

# GS/DURAPULSE Drives Accessories – Line Reactors

460 & 575 Volt Three Phase Input / Output Reactors							
Part Number	Rated Amps	Impedance	Inductance	Watt Loss	Drive Model and Side / Phase / Volts	Drive hp	
<b>GS-41P0-LR</b>	2	3%	12.0 mH	7	GS2-41P0 (in/out) / 3ph / 460V GS3-41P0 (in/out) / 3ph / 460V	1	
<b>GS-42P0-LR</b>	4	3%	6.50 mH	13	GS2-42P0 (in/out) / 3ph / 460V GS2-53P0 (in/out) / 3ph / 575V GS3-42P0 (in/out) / 3ph / 460V	2 3 2	
<b>GS-43P0-LR</b>	8	3%	5.00 mH	31	GS2-43P0 (in/out) / 3ph / 460V GS2-55P0 (in/out) / 3ph / 575V GS3-43P0 (in/out) / 3ph / 460V	3 5 3	
<b>GS-45P0-LR</b>	8	3%	3.00 mH	25	GS2-45P0 (in/out) / 3ph / 460V GS3-45P0 (in/out) / 3ph / 460V	5	
<b>GS-47P5-LR</b>	12	3%	2.50 mH	26	GS2-47P5 (in/out) / 3ph / 460V GS2-57P5 (in/out) / 3ph / 575V GS2-5010 (in/out) / 3ph / 575V GS3-47P5 (in/out) / 3ph / 460V	7.5 7.5 10 7.5	
<b>GS-4010-LR</b>	18	3%	1.50 mH	29	GS2-4010 (in/out) / 3ph / 460V GS3-4010 (in/out) / 3ph / 460V	10	
<b>GS-4015-LR</b>	25	3%	1.20 mH	44	GS3-4015 (in/out) / 3ph / 460V	15	
<b>GS-4020-LR</b>	35	3%	0.80 mH	51	GS3-4020 (in/out) / 3ph / 460V	20	
<b>GS-4025-LR</b>	35	3%	0.80 mH	51	GS3-4025 (in/out) / 3ph / 460V	25	
<b>GS-4030-LR</b>	45	3%	0.70 mH	64	GS3-4030 (in/out) / 3ph / 460V	30	
<b>GS-4040-LR</b>	55	3%	0.50 mH	75	GS3-4040 (in/out) / 3ph / 460V	40	
<b>GS-4050-LR</b>	80	3%	0.40 mH	138	GS3-4050 (in/out) / 3ph / 460V	50	
<b>GS-4060-LR</b>	80	3%	0.40 mH	138	GS3-4060 (in/out) / 3ph / 460V	60	
<b>GS-4075-LR</b>	110	3%	0.30 mH	123	GS3-4075 (in/out) / 3ph / 460V	75	
<b>GS-4100-LR</b>	130	3%	0.20 mH	115	GS3-4100 (in/out) / 3ph / 460V	100	
<b>GS-51P0-LR</b>	2	3%	20.0 mH	9	GS2-51P0 (in/out) / 3ph / 575V	1	
<b>GS-52P0-LR</b>	4	3%	9.10 mH	15	GS2-52P0 (in/out) / 3ph / 575V	2	

PLC Overview

DL05/06 PLC

DL105 PLC

DL205 PLC

DL305 PLC

DL405 PLC

Field I/O

Software

C-more HMIs

Other HMI

AC Drives

Motors

Steppers/ Servos

Motor Controls

Proximity Sensors

Photo Sensors

Limit Switches

Encoders

Pushbuttons/ Lights

Process

Relays/ Timers

Comm.

TB's & Wiring

Power

Enclosures

Appendix

Part Index

# GS/DURAPULSE Drives Accessories – Line Reactors

AC Line Reactor Dimensions (inches)							
Part Number	H	W	D	Mtg D	Mtg W	Mtg Slot Hole Size	Weight (lbs)
GS-10P2-LR	4.80	6.00	3.30	2.09	2.00	0.28 x 0.63	7.10
GS-10P5-LR	5.7	6.00	3.09	2.09	3.00	0.28 x 0.63	7.00
GS-11P0-LR	5.7	6.00	3.34	2.34	3.00	0.28 x 0.63	8.90
GS-20P5-LR-1PH	3.40	4.40	2.83	1.77	1.44	0.28 x 0.63	2.80
GS-20P5-LR-3PH	3.40	4.40	2.83	1.77	1.44	0.28 x 0.63	2.80
GS-21P0-LR-1PH	3.40	4.40	2.83	1.77	1.44	0.28 x 0.63	2.80
GS-21P0-LR-3PH	3.40	4.40	2.83	1.77	1.44	0.28 x 0.63	2.30
GS-22P0-LR-1PH	3.40	4.40	2.83	1.77	2.00	0.28 x 0.63	3.10
GS-22P0-LR-3PH	3.40	4.40	2.83	1.77	2.00	0.28 x 0.63	2.80
GS-23P0-LR-1PH	4.80	6.00	3.30	2.09	2.00	0.28 x 0.63	7.50
GS-23P0-LR-3PH	3.40	4.40	2.83	1.77	2.00	0.28 x 0.63	2.90
GS-25P0-LR	4.80	6.00	3.30	2.09	2.00	0.28 x 0.63	7.10
GS-27P5-LR	5.70	6.00	3.09	2.09	3.00	0.28 x 0.63	7.00
GS-2010-LR	5.70	6.00	3.34	2.34	3.00	0.28 x 0.63	9.00
GS-2015-LR	5.70	6.00	3.84	2.84	3.00	0.28 x 0.63	13.0
GS-2020-LR	5.70	6.00	3.84	2.84	3.00	0.28 x 0.63	12.0
GS-2025-LR	6.88	8.50	4.37	3.12	3.60	0.44 x 1.00	26.0
GS-2030-LR	6.88	8.50	4.37	3.12	3.60	0.44 x 1.00	26.0
GS-2040-LR	6.88	8.50	4.37	3.12	3.00	0.44 x 1.00	27.0
GS-2050-LR	6.88	8.50	4.37	3.12	3.00	0.44 x 1.00	27.0
GS-41P0-LR	3.40	4.40	2.83	1.77	1.44	0.28 x 0.63	2.30
GS-42P0-LR	3.40	4.40	2.83	1.77	1.44	0.28 x 0.63	2.80
GS-43P0-LR	3.40	4.40	3.39	2.39	2.00	0.28 x 0.63	4.30
GS-45P0-LR	3.40	4.40	2.83	1.77	2.00	0.28 x 0.63	3.10
GS-47P5-LR	4.80	6.00	3.30	2.09	2.00	0.28 x 0.63	7.50
GS-4010-LR	4.80	6.30	3.55	2.34	2.00	0.28 x 0.63	9.10
GS-4015-LR	5.70	6.00	3.34	2.34	3.00	0.28 x 0.63	10.0
GS-4020-LR	5.61	6.90	3.95	2.75	3.00	0.38 x 0.63	17.0
GS-4025-LR	5.61	6.90	3.95	2.75	3.00	0.38 x 0.63	17.0
GS-4030-LR	5.61	6.90	4.45	3.25	3.00	0.38 x 0.63	22.0
GS-4040-LR	6.88	8.50	4.37	3.12	3.00	0.44 x 1.00	26.0
GS-4050-LR	6.88	8.50	4.87	3.62	3.60	0.44 x 1.00	36.0
GS-4060-LR	6.88	8.50	4.87	3.62	3.60	0.44 x 1.00	36.0
GS-4075-LR	8.29	10.50	5.35	3.73	3.60	0.44 x 1.25	52.0
GS-4100-LR	8.29	10.50	5.35	3.73	3.60	0.44 x 1.25	41.0
GS-51P0-LR	3.40	4.40	2.83	1.77	1.44	0.28 x 0.63	3
GS-52P0-LR	3.40	4.40	2.83	1.77	1.44	0.28 x 0.63	3

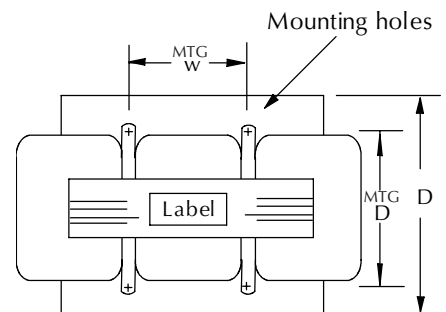
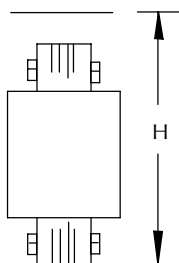
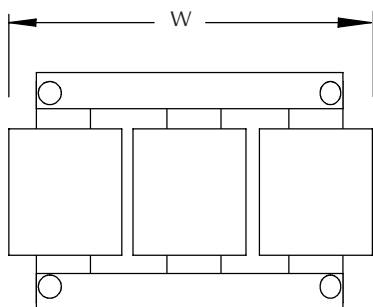

# GS/DURAPULSE Drives Accessories – Line Reactors

## Input side of the drive

When installed on the input side of the AC drive, line reactors will reduce line notching, and limit current and voltage spikes and surges from the incoming line. The line reactor will also reduce harmonic distortion from the drive onto the line. Units are installed in front of the AC drive as shown.

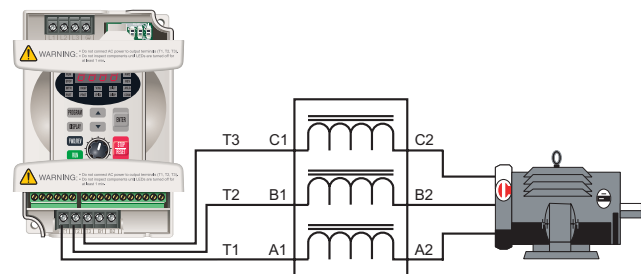
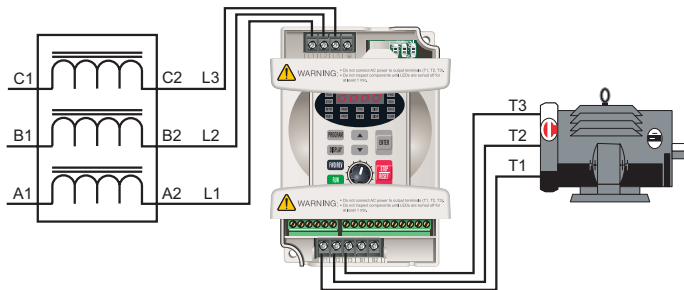

## Output side of the drive

When installed on the output side of the drive, line reactors protect the drive from short circuits at the load. Voltage and current waveforms from the drive are enhanced, reducing motor overheating and noise emissions.

**Note: Single phase line reactors should not be installed on the output of the AC Drive. Use three-phase only.**

## Multiple drives

Individual line reactors are recommended when installing multiple drives on the same power line. Individual line reactors eliminate cross talk between multiple drives and provide isolated protection for each drive for its own specific load.

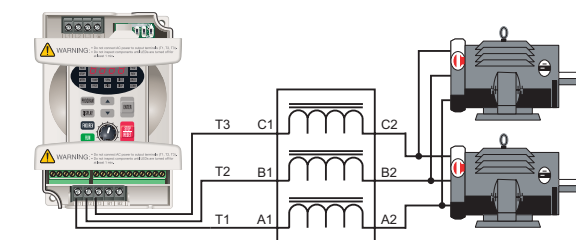
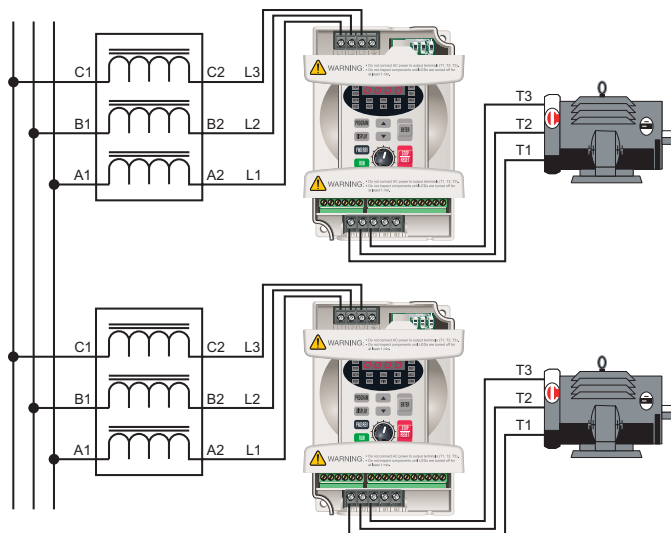

## Multiple motors

A single reactor can be used when the application calls for multiple motors on the same drive. The reactor is sized based upon the total horsepower of all the motors. **Overload relays (not shown) are recommended** for use in multi-motor applications.

**Note: A single reactor should only be used with multiple motors when the motors will always operate simultaneously.**

## Single phase applications

Some of the line reactors are listed for use with single-phase input power. Follow the connection diagram to the left. Make sure that terminals B1 and B2 are properly insulated before any connections are made.



**WARNING:** Please ensure that terminals B1 and B2 are properly insulated before making any connections to single-phase power.

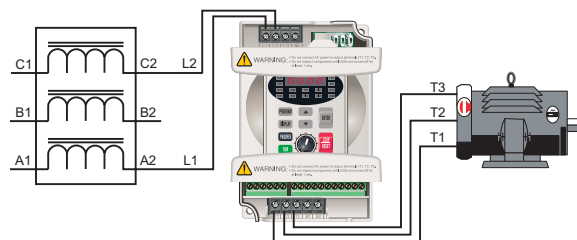

PLC Overview

DL05/06 PLC

DL105 PLC

DL205 PLC

DL305 PLC

DL405 PLC

Field I/O

Software

C-more HMIs

Other HMI

AC Drives

Motors

Steppers/Servos

Motor Controls

Proximity Sensors

Photo Sensors

Limit Switches

Encoders

Pushbuttons/Lights

Process

Relays/Timers

Comm.

TB's & Wiring

Power

Enclosures

Appendix

Part Index