

Fuji Duo Series TK-E Overload Relays

TK-E series thermal overload relays with open-phase protective device

Features

- This relay protects motor windings from burning due to overloads, locked rotor current, or open-phases
- Maintenance and inspection safety has been improved by employing a finger protection mechanism to cover exposed terminals (conforms to DIN 57106, VDE 0106 Teil 100)
- Isolated NO and NC contacts can be used with different potentials
- A high-precision scale for the current adjustment dial enables easy and exact current setting
- The operating status can be visually checked with ease
- The relays can be manually tripped. A trip-free mechanism is also provided
- Base unit can be added to enable separate mounting of the TK-E02, E2, and E3-xxx models



TK-E02-900



TK-E3-5000



TK-E2-800



TK-E5-3600



Standards

UL listed, file E44592, Standard UL 508
 cUL listed, file E44592, CSA C22.2 No. 14
 IEC 60947-4-1, EN60947-4-1
 VDE 0660, JIS C 8201-4-1
 CE Compliant

TK-E Series Overloads			
Part Number	Amperage Adjustment Range (A)	Frame Width/Contactor	
TK-E02-15	0.1 - 0.15	53mm SC-E02(G) through SC-E05(G) For separate mounting, use with optional base unit SZ-HCE on page 16-24	
TK-E02-20	0.13 - 0.2		
TK-E02-24	0.15 - 0.24		
TK-E02-30	0.2 - 0.3		
TK-E02-36	0.24 - 0.36		
TK-E02-54	0.36 - 0.54		
TK-E02-72	0.48 - 0.72		
TK-E02-96	0.64 - 0.96		
TK-E02-120	0.8 - 1.2		
TK-E02-145	0.95 - 1.45		
TK-E02-220	1.4 - 2.2		
TK-E02-260	1.7 - 2.6		
TK-E02-340	2.2 - 3.4		
TK-E02-420	2.8 - 4.2		
TK-E02-600	4.0 - 6.0		
TK-E02-800	5.0 - 8.0		
TK-E02-900	6.0 - 9.0		
TK-E02-1100	7.0 - 11.0		
TK-E02-1300	9.0 - 13.0		
TK-E02-1800	12 - 18		
TK-E02-2200	16 - 22		
TK-E02-2500	20 - 25		

TK-E Series Overloads (continued)			
Part Number	Amperage Adjustment Range (A)	Frame Width/Contactor	
TK-E2-600	4 - 6	54mm SC-E1(G) through SC-E2S(G) For separate mounting, use with optional base unit SZ-HDE on page 16-24	
TK-E2-800	5 - 8		
TK-E2-900	6 - 9		
TK-E2-1100	7 - 11		
TK-E2-1300	9 - 13		
TK-E2-1800	12 - 18		
TK-E2-2600	18 - 26		
TK-E2-3600	24 - 36		
TK-E2-4200	32 - 42		
TK-E2-5000	40 - 50		
TK-E2-5400	44 - 54		
TK-E3-1100	7 - 11	68mm SC-E3(G) through SC-E4(G) For separate mounting, use with optional base unit SZ-HEE on page 17-24	
TK-E3-1300	9 - 13		
TK-E3-1800	12 - 18		
TK-E3-2600	18 - 26		
TK-E3-3600	24 - 36		
TK-E3-4000	28 - 40		
TK-E3-5000	34 - 50		
TK-E3-6500	45 - 65		
TK-E3-6800	48 - 68		
TK-E3-8000	64 - 80		



TK-E6-6500

TK-E Series Overloads (continued)					
Part Number	Amperage Adjustment Range (A)	Frame Width/Contactor			
TK-E5-2600	18 - 26	76.5mm SC-E5			
TK-E5-3600	24 - 36				
TK-E5-4000	28 - 40				
TK-E5-5000	34 - 50				
TK-E5-6500	45 - 65				
TK-E5-9500	65 - 95				
TK-E5-10500	85 - 105				
TK-E6-6500	45 - 65			100mm SC-E6 SC-E7	
TK-E6-8000	53 - 80				
TK-E6-9500	65 - 95				
TK-E6-12500	85 - 125				
TK-E6-16000	110 - 160				

Fuji Duo Series Contactor and Overload Relay Selection Tables

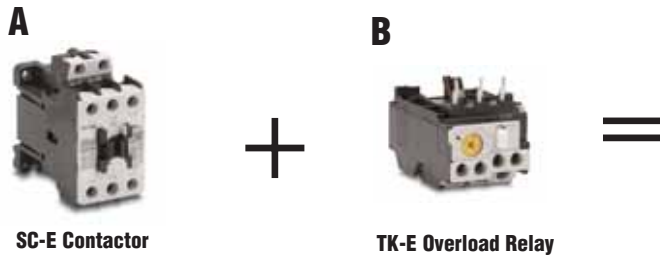

100-240V Single Phase Motor (1/3 to 25 hp)

Step 1. Select a contactor from page 16–5 based on motor voltage and horsepower.

Step 2. Select an overload relay from page 16–19 based on motor full load current.

Check the data plate on the motor for the hp, volts and full-rated amps.

Motor				
HP	5	Volts	460	Phase 3
RPM	1725	Amps	7.6	Hz 60
Design	B	AMB	40°C	Insul Class F
Duty	Cont	Encl	TEFC	Code K

Motor horsepower

Motor voltage

Motor full-load rated amperage (FLA)

Three Phase Motors - Refer to tables on following page

Step 1. Select a SC-E contactor from Column A based on motor voltage, horsepower, and required coil voltage.

Step 2. Select a TK-E overload relay from Column B to work with the SC-E contactor selected in Step 1. The motor full load current (FLA) should be within the adjustable current range of the overload relay.

Fuji Duo Series Contactor and Overload Relay Selection Tables

220-240V Three Phase Motor (0.5 to 50 hp)¹

Motor Rating		A				B	
HP	Motor Full Load Amperage (FLA) ²	Contactor (choose coil voltage below)				Overload Relay	
		24VAC Coil	110-120VAC Coil	220-240VAC Coil	24VDC Coil	Part Number	Adjustable Current Range
1/2	2.2	SC-E02-24VAC	SC-E02-110VAC	SC-E02-220VAC	SC-E02G-24VDC	TK-E02-260	1.7 to 2.6 Amps
3/4	3.5					TK-E02-420	2.8 to 4.2 Amps
1	4.2					TK-E02-600	4 to 6 Amps
1-1/2	6					TK-E02-800	5 to 8 Amps
2	6.8					TK-E02-900	6 to 9 Amps
3	9.6	SC-E03-24VAC	SC-E03-110VAC	SC-E03-220VAC	SC-E03G-24VDC	TK-E02-1300	9 to 13 Amps
5	15.2	SC-E04-24VAC	SC-E04-110VAC	SC-E04-220VAC	SC-E04G-24VDC	TK-E02-1800	12 to 18 Amps
7-1/2	22	SC-E05-24VAC	SC-E05-110VAC	SC-E05-220VAC	SC-E05G-24VDC	TK-E02-2500	20 to 25 Amps
10	28	SC-E1-24VAC	SC-E1-110VAC	SC-E1-220VAC	SC-E1G-24VDC	TK-E2-3600	24 to 36 Amps
15	42	SC-E2-24VAC	SC-E2-110VAC	SC-E2-220VAC	SC-E2G-24VDC	TK-E2-4200	32 to 42 Amps
20	54	SC-E3-24VAC	SC-E3-110VAC	SC-E3-220VAC	SC-E3G-24VDC	TK-E3-6500	45 to 65 Amps
25	68	SC-E4-24VAC	SC-E4-110VAC	SC-E4-220VAC	SC-E4G-24VDC	TK-E3-6800	48 to 68 Amps
30	80	SC-E5-24V*	SC-E5-100V*	SC-E5-200V*	SC-E5-24V*	TK-E5-9500	65 to 95 Amps
40	104	SC-E6-24V*	SC-E6-100V*	SC-E6-200V*	SC-E6-24V*	TK-E6-12500	85 to 125 Amps
50	130	SC-E7-24V*	SC-E7-100V*	SC-E7-200V*	SC-E7-24V*	TK-E6-16000	110 to 160 Amps

* SUPERMAGNET coil operates with AC or DC voltage.

¹ For 220-240 V three-phase motors up to 150 hp refer to the Fuji Odyssey series.

² Per NEC 2005 table 430.250

440-480V Three Phase Motor (0.5 to 100 hp)¹

Motor Rating		A				B	
HP	Motor Full Load Amperage (FLA) ²	Contactor (choose coil voltage below)				Overload Relay	
		24VAC Coil	110-120VAC Coil	220-240VAC Coil	24VDC Coil	Part Number	Adjustable Current Range
1/2	1.1	SC-E02-24VAC	SC-E02-110VAC	SC-E02-220VAC	SC-E02G-24VDC	TK-E02-145	0.95 to 1.45 Amps
3/4	1.6	SC-E02-24VAC	SC-E02-110VAC	SC-E02-220VAC	SC-E02G-24VDC	TK-E02-220	1.4 to 2.2 Amps
1	2.1	SC-E02-24VAC	SC-E02-110VAC	SC-E02-220VAC	SC-E02G-24VDC	TK-E02-260	1.7 to 2.6 Amps
1-1/2	3.0	SC-E02-24VAC	SC-E02-110VAC	SC-E02-220VAC	SC-E02G-24VDC	TK-E02-420	2.8 to 4.2 Amps
2	3.4	SC-E02-24VAC	SC-E02-110VAC	SC-E02-220VAC	SC-E02G-24VDC	TK-E02-420	2.8 to 4.2 Amps
3	4.8	SC-E02-24VAC	SC-E02-110VAC	SC-E02-220VAC	SC-E02G-24VDC	TK-E02-600	4 to 6 Amps
5	7.6	SC-E02-24VAC	SC-E02-110VAC	SC-E02-220VAC	SC-E02G-24VDC	TK-E02-900	6 to 9 Amps
7 1/2	11	SC-E03-24VAC	SC-E03-110VAC	SC-E03-220VAC	SC-E03G-24VDC	TK-E02-1300	9 to 13 Amps
10	14	SC-E04-24VAC	SC-E04-110VAC	SC-E04-220VAC	SC-E04G-24VDC	TK-E02-1800	12 to 18 Amps
15	21	SC-E05-24VAC	SC-E05-110VAC	SC-E05-220VAC	SC-E05G-24VDC	TK-E02-2500	20 to 25 Amps
20	27	SC-E1-24VAC	SC-E1-110VAC	SC-E1-220VAC	SC-E1G-24VDC	TK-E2-3600	24 to 36 Amps
25	34	SC-E1-24VAC	SC-E1-110VAC	SC-E1-220VAC	SC-E1G-24VDC	TK-E2-4200	32 to 42 Amps
30	40	SC-E2-24VAC	SC-E2-110VAC	SC-E2-220VAC	SC-E2G-24VDC	TK-E2-4200	32 to 42 Amps
40	52	SC-E3-24VAC	SC-E3-110VAC	SC-E3-220VAC	SC-E3G-24VDC	TK-E3-6500	45 to 65 Amps
50	65	SC-E4-24VAC	SC-E4-110VAC	SC-E4-220VAC	SC-E4G-24VDC	TK-E3-6800	48 to 68 Amps
60	77	SC-E5-24V*	SC-E5-100V*	SC-E5-200V*	SC-E5-24V*	TK-E5-9500	65 to 95 Amps
75	96	SC-E6-24V*	SC-E6-100V*	SC-E6-200V*	SC-E6-24V*	TK-E6-12500	85 to 125 Amps
100	124	SC-E7-24V*	SC-E7-100V*	SC-E7-200V*	SC-E7-24V*	TK-E6-16000	110 to 160 Amps

* SUPERMAGNET coil operates with AC or DC voltage.

¹ For 440-480 V three-phase motors up to 300 hp refer to the Fuji Odyssey series.

² Per NEC 2005 table 430.250

Fuji Duo Series TK-E Overload Relays



Standard Operating Conditions	
Ambient Temperature	Operating: -5 to 55°C No sudden temperature changes resulting in condensation or icing (The average temperature over a 24-hour period must not exceed 35°C) Storage: -40 to 65°C
Humidity	45 to 85%RH
Atmosphere	No excessive dust, smoke, corrosive gases, flammable gases, steam, or salt
Vibration	10 to 55Hz, 15m/s ²
Shock	50m/s ²

Specifications						
Model	Applicable Contactor Non-reversing	Auxiliary Contact	Trip Class IEC 60947-4-1	No. of Heater Elements	Power Consumption per Pole (VA)	Features
TK-E02-xxx	SC-E02, E03, E04, E05-xxx	1NO+1NC	10A	3	2.2	Overload, open-phase protection, Ambient temperature compensation, Manual/auto reset selectable, Manual trip mechanism, Trip indicator
TK-E2-xxx	SC-E1, E2, E2S-xxx				3.8	
TK-E3-xxx	SC-E3, E4-xxx				6.6	
TK-E5-xxx	SC-E5-xxx				6.6	
TK-E6-xxx	SC-E6, E7-xxx				8.0	

Auxiliary Contact Ratings - UL and CSA						
Model	Rated Insulation Voltage (V)	NEMA ICS 5-2000 Ratings (note 1)				
		AC Ratings			DC Ratings	
		Designation	Making VA	Breaking VA	Designation	Making/Breaking VA
TK-E02-xxx to TK-E6-xxx	690	B600	3600	360	R300	28

Notes:
1. NEMA ICS 5-2000. For more information, refer to Control Circuit Contact Electrical Ratings, page 16-75.

Auxiliary contact ratings - JIS and IEC							
Model	Rated Insulation Voltage (A)	Rated Thermal Current (A)	Rated Operational Current (A)				Minimum Voltage and Current
			AC Voltage (V)	AC15 (Ind. load)	DC Voltage (V)	DC13 (Ind. load)	
TK-E02-xxx	690	5	24	3 (0.3) *	24	1.1 (0.3)	3VDC, 5mA
			100-120	2.5 (0.3) *	100-120	0.28	
			200-240	2 (0.3) *	200-240	0.14	
			380-440	1 (0.3) *			
			500-600	0.6 (0.3) *			
TK-E2-xxx	690	5	24	3 (0.5) *	24	1.1 (0.3)	3VDC, 5mA
TK-E3-xxx			100-120	2.5 (0.5) *	100-120	0.28	
TK-E5-xxx			200-240	2 (0.5) *	200-240	0.14	
TK-E6-xxx			380-440	1 (0.5) *			
			500-600	0.6 (0.5) *			

Note: * In case of auto-reset type NO contact.

Fuji Duo Series TK-E Overload Relays

Wiring



Be sure to wire the relays correctly using the wiring diagrams on the supplied installation sheets. Main terminals for models TK-E02-xxx to TK-E6-xxx are wired using solid wires or stranded wires. Stranded wires or flexible stranded wires can be connected by twisting them together and crimping a sleeve (ferrule) onto them before connecting.



Tightening torque

If wires are not tightened sufficiently, they may become hot or loosen and result in a fire, short-circuit, electric shock, or some other potentially dangerous situation. Be sure to tighten the wires to the torques specified in these tables.



Wire Sizes, Tightening Torques - Main Circuit				
Thermal Overload Relay Model	TK-E2-xxx	TK-E3-xxx	TK-E5-xxx	TK-E6-xxx
Single Stranded Wire (mm ²)	0.75 to 16	1.5 to 35		16 to 70
Flexible Stranded Wire with Sleeve (mm ²)	0.75 to 16	1.5 to 35		16 to 70
Flexible Stranded Wire without Sleeve (mm ²)	0.75 to 16	1.5 to 35		16 to 70
AWG	6 max.	2 max.		00 max.
Insulation Stripping Length				
Tool	Phillips screwdriver, H-type, No. 2 (ISO 8764); ADC part number DN-SP1 or DN-SP2 Flat-blade screwdriver, 1 x 5.5 x L-type, B (ISO 2830); ADC part number DN-SS5	Hex. wrench 4 (ISO 2936)		
Tightening Torque (N·m)	2.5	6		10

Note: Stranded wire (0 to 25mm²) consists of 7 wires or less. Stranded wire (35 to 120mm²) consists of 19 wires or less. Flexible stranded wire consists of more wires than the above.

Wire Sizes, Tightening Torques - Main Circuit	
Thermal Overload Relay Type	TK-E02-xxx
Solid Wire (mm ²)	One 0.75 to 4
	Two 1 to 4
Stranded Wire (mm ²)	One 0.75 to 4
	Two 1 to 4
AWG	One 12 max.
	Two 12 max.
Insulation Stripping Length (mm)	
Terminal Screw Size	M4
Tool	Phillips screwdriver, H-type, No. 2 (ISO 8764); ADC part number DN-SP1 or DN-SP2 Flat-blade screwdriver, 1 x 5.5 x L-type, B (ISO 2830); ADC part number DN-SS5
Tightening Torque [N·m (lb·in)]	1.2 to 1.5 (11 to 13)

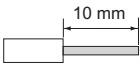
Wire Sizes, Tightening Torques - Control Circuit	
Single Stranded Wire (mm ²)	One 0.75 to 2.5 (ø 1 to ø 1.6)
	Two 0.75 to 2.5
AWG	One 18 to 14
	Two 18 to 14
Insulation Stripping Length (mm)	
Fork Terminal	Max. 7.7mm wide (R2-3.5)
Terminal Screw Size	M3.5
Tool	Phillips screwdriver, H-type, No. 2 (ISO 8764); ADC part number DN-SP1 or DN-SP2 Flat-blade screwdriver, 1 x 5.5 x L-type, B (ISO 2830); ADC part number DN-SS5
Tightening Torque [N·m (lb·in)]	0.8 to 1 (7 to 9)

Fuji Duo Series TK-E Overload Relays

Operating characteristics

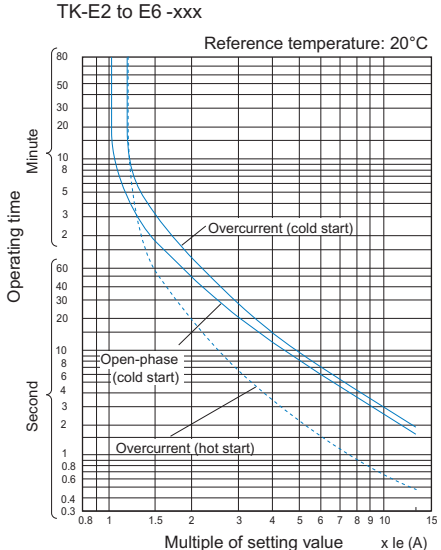
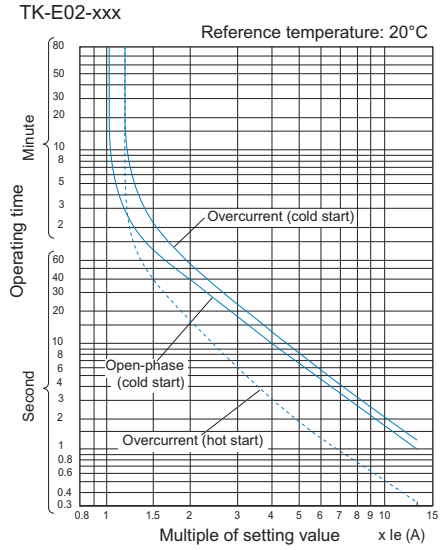

Optional accessories

Base units for separate mounting

Allows TK-E02, E2, and E3 series thermal overload relays to be separately mounted to 35mm wide DIN rail, or screw mounted to panel.

Mounting Base Unit	
Part Number	Applicable Overload Relays
SZ-HCE	TK-E02-xxx
SZ-HDE	TK-E2-xxx
SZ-HEE	TK-E3-xxx

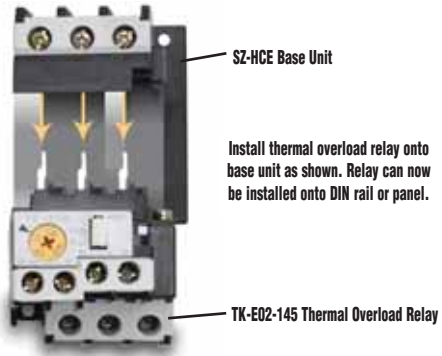

SZ-HCE

SZ-HCE

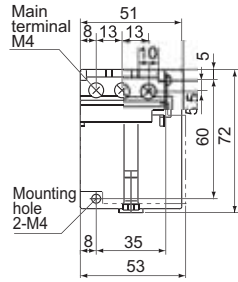
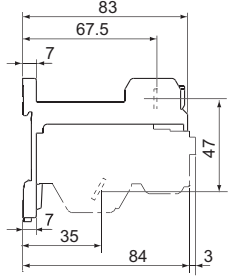

SZ-HDE

SZ-HDE

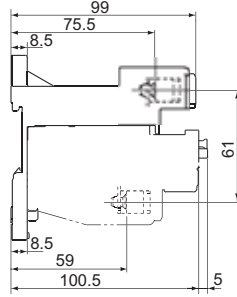

SZ-HEE

SZ-HEE

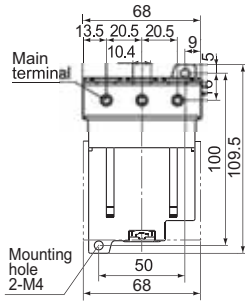
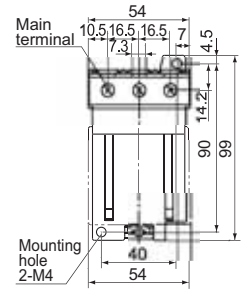
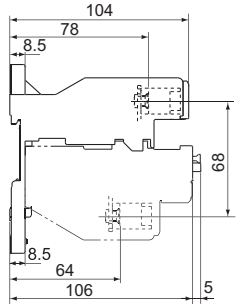

Fuji Duo Series TK-E Overload Relays

Dimensions (mm)

Overload relays

TK-E02-xxx

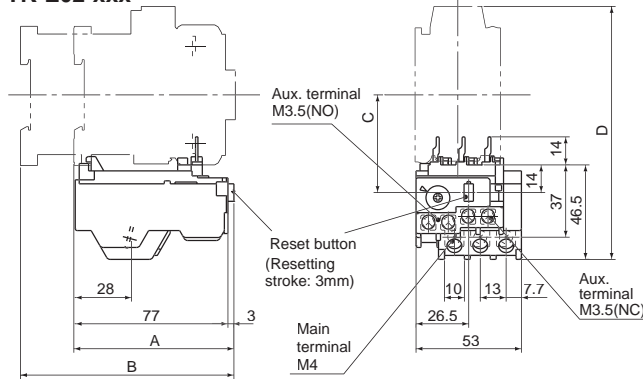

Contactor	A	B	C	D	
SC-E02 to 05	80.5	-	49	127.5	Weight: 0.13kg
SC-E02G to 05G	-	107.5	49	127.5	

TK-E2-xxx

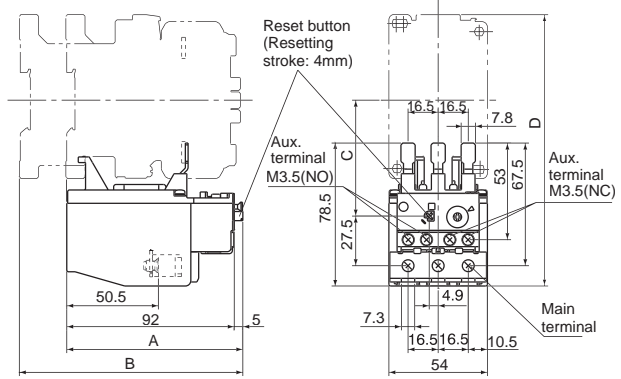

Contactor	A	B	C	D	
SC-E1 to E2S	97	-	63.5	149	Weight: 0.25kg
SC-E1G to E2SG	-	123	63.5	149	

TK-E3-xxx

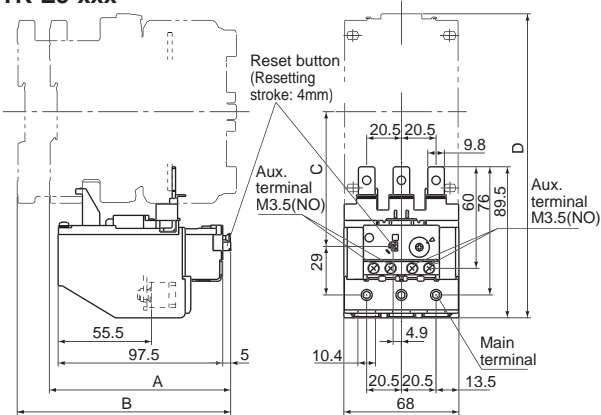

Contactor	A	B	C	D	
SC-E3, E4	107.5	-	79.5	180	Weight: 0.34kg
SC-E3, E4G	-	126.5	79.5	180	

TK-E5-xxx

On-contactor mounting only

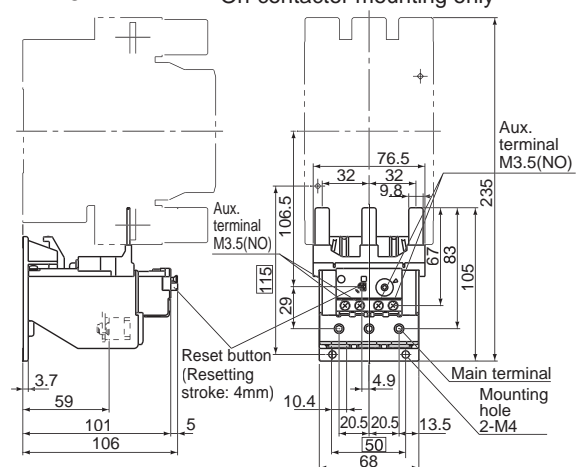

Weight: 0.37kg

TK-E6-xxx

On-contactor mounting only

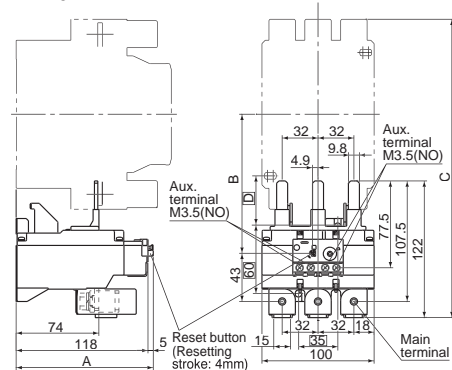

Contactor	A	B	C	D	
SC-E6	123	124	266.5	45	Weight: 0.71kg
SC-E7	123	129	274	50	

Wiring diagram

3-heater element

