

# FC Series Signal Conditioners

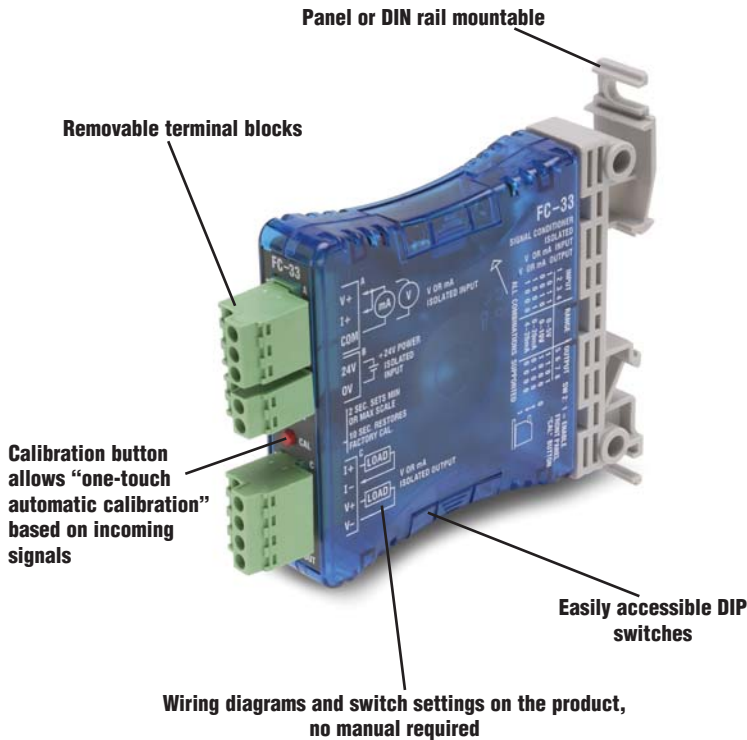

## Convert, isolate and transmit your process signals

Not all electrical signals are created equal. That's why the FC series signal conditioners are the perfect solution for converting process, temperature and other electrical signals into voltage or current signals for transmission or input to a PLC.

The FC series signal conditioners offer 1500V isolation between the input and output to help eliminate electrical noise. Features include easily accessible potentiometer adjustment of the output span and offset, (with the exception of FC-33), slim DIN-rail or side-mount cases and removable terminal blocks.

The FC series signal conditioners are ideal for use with PLCs, loop controllers, digital displays and any other applications requiring an isolated or analog signal.



### FC-33

#### DC Selectable Signal Conditioner with 3-way isolation

Field configurable input and output ranges of 0-5V, 0-10V, 0-20 mA and 4-20 mA with 1500 VDC isolation between input and output, and 1500 VDC isolation from 24 volt power and input/output. LED indicates normal operation and is used in conjunction with the calibration pushbutton for the internal calibration process.

- 3-way 1500V isolation
- Push button calibration



### FC-T1

#### Thermocouple/mV Isolated Signal Conditioner

Field configurable input for several different types of thermocouple or mV inputs with 1500 VDC isolation between input and output. Cold junction compensation and burnout detection. Alarm/run LED.

- 1500V isolation
- Cold junction compensation (CJC)
- Internal diagnostics (burnout detection or calibration errors)



### FC-11

#### 4-20 mA Isolated Signal Conditioner

Loop powered 4-20 mA input/output signal with 1500 VDC isolation between input and output.

- 1500V isolation
- Loop powered



### FC-R1

#### RTD Input Signal Conditioner

Loop powered, non-isolated, 3-wire unit converts an RTD input to a linear 4-20 mA signal. User selectable CU10, PT100 or PT1000 input.

PLC Overview

DL05/06 PLC

DL105 PLC

DL205 PLC

DL305 PLC

DL405 PLC

Field I/O

Software

C-more HMIs

Other HMI

AC Drives

Motors

Steppers/Servos

Motor Controls

Proximity Sensors

Photo Sensors

Limit Switches

Encoders

Pushbuttons/Lights

Process

Relays/Timers

Comm.

TB's & Wiring

Power

Enclosures

Appendix

Part Index

# FC-33 DC Selectable Signal Conditioner



## Overview

The FC-33 is a DIN-rail or side-mount, selectable input/output signal conditioner with 1500 VDC isolation between input and output, and 1500 VDC isolation between 24-volt power and input/output. The field configurable input/output types allow a wide ranging capability for 0-5V, 0-10V, 0-20 mA and 4-20 mA signals. The FC-33 has built-in self-calibration, but also has OFFSET (zero) and SPAN (full scale) adjustments of the output signal. The OFFSET has an adjustment range of 0 to 25% of full scale input and the SPAN has an adjustment of 80% to 102%.

**Level LED:** The LED is a powerful tool when setting up the signal conditioner. During normal operation the LED will blink at a proportional rate to the selected input signal level. When performing field calibration the LED is used for indication of the internal calibration process.

**CAL-Pushbutton:** This pushbutton, along with various switch settings, allows you to calibrate the OFFSET and/or SPAN for your application or to restore factory default calibration.

## Application

The FC-33, field configurable isolated input/output signal conditioner, is useful in eliminating ground loops and interfacing sensors to PLC analog input modules. The FC-33 has 3-way isolation; this feature solves many types of configuration problems. For example, the signal conditioner can be configured for a sinking input and a sourcing output. It also allows signal translation from current input to voltage output or voltage input to current output.

This feature would be useful in a system design with a limited type and number of channels – for example: eight channels of 0-10 VDC, seven of which are used, and one 4-20 mA input transmitter.

See page 22–13 for signal conditioner dimensions.

Specifications	
<b>Input Ranges</b>	0-5 V, 0-10 V, 0-20 mA, 4-20 mA
<b>Input Impedance</b>	250 $\Omega$ , $\pm 0.1\%$ current input 200 K $\Omega$ / 400 K $\Omega$ Voltage input
<b>Output Ranges</b>	0-5 V, 0-10 V, 0-20 mA, 4-20 mA
<b>Load Impedance</b>	2 K $\Omega$ minimum, voltage output 0 $\Omega$ minimum, current output
<b>Maximum Load / Current</b>	550 $\Omega$ @ 24 VDC (sink/source)
<b>Sample Duration Time</b>	10 mS
<b>Filter Characteristic</b>	-3 dB @ 3 Hz, -6 dB/octave
<b>Linearity Error</b>	0.05% FSO maximum
<b>Stability</b>	0.05% FSO maximum
<b>Accuracy vs. Temperature</b>	0.005%/°C, (50ppm/°C)
<b>Input Power</b>	24 VDC, $\pm 10\%$ @ 50 mA
<b>Recommended Fuse</b>	0.032 mA, Series 217, current inputs
<b>Isolation</b>	1500 VDC input - output* 1500 VDC power - input* 1500 VDC power - output* *applied for 1 second
<b>Maximum Inaccuracy of Output</b>	0.05% @ 25°C, FSO maximum 0.25% @ 0-60°C, FSO maximum
<b>Output Current</b>	21 mA maximum (for mA output)
<b>Approx. Field Cal. Range</b>	0 - 25% (0 - 1.5 V / 5 V mode) 80% - 102% (4 - 5.1 V / 5 V mode)
<b>Operating Temperature</b>	0-60°C (32 to 140°F)
<b>Storage Temperature</b>	-20 to 70°C (-4 to 158°F)
<b>Relative Humidity</b>	5 to 90% (non-condensing)
<b>Vibration</b>	ML STD 810C 514.2
<b>Shock</b>	ML STD 810C 516.2
<b>Noise Immunity</b>	NEMA ICS3-304

## Typical User Wiring

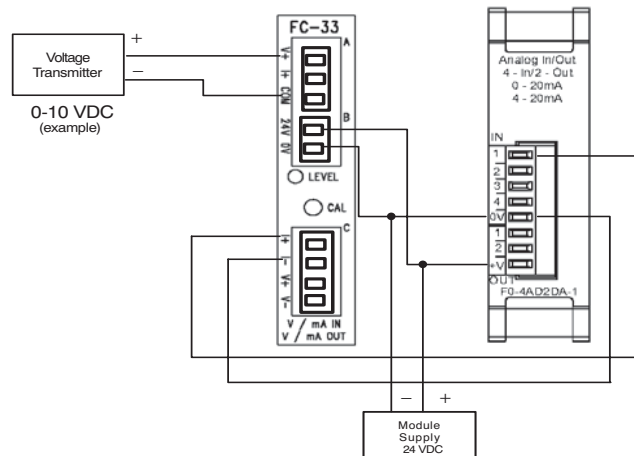

Voltage Input and Current Output (example)

# FC-11 4-20mA Isolated Signal Conditioner



## Overview

The FC-11 is a DIN-rail or side-mount, 4-20 mA Input/Output loop powered signal conditioner with 1500 VDC isolation between input and output.

The FC-11 has a user-selectable factory calibration. The output can also be calibrated with OFFSET (zero) and SPAN (full scale) adjustments. The OFFSET has an adjustment range of 0 to 25% of full scale input and the SPAN has an adjustment of 80% to 102%.

## Application

The FC-11 isolated input/output signal conditioner is useful in eliminating ground loops and sinking/sourcing issues when interfacing to PLC analog input modules. The FC-11 design feature solves many types of configuration problems. For example, the signal conditioner can solve the problem of connecting a sinking input transmitter to a sinking analog input module.

Specifications	
<b>Input Ranges</b>	4-20 mA
<b>Extended Input range<sup>1</sup></b>	3.5 mA to 20.6 mA, ±1%
<b>Input Burden Voltage<sup>2</sup></b>	6.8 VDC
<b>Maximum Input Current</b>	34 mA @ 9.7 VDC
<b>Output Burden Voltage<sup>3</sup></b>	8.5 VDC minimum
<b>Output Range</b>	4-20 mA
<b>Extended Output Range<sup>1</sup></b>	3.5 mA to 20.6 mA, ±1%
<b>Maximum Load Impedance</b>	650 Ω @ 24 VDC, 1000 Ω @ 29 VDC
<b>Maximum Output Current</b>	23 mA @ 29 VDC
<b>Sample Duration Time</b>	18 mS maximum
<b>Filter Characteristic</b>	-3 dB @ 200 Hz -6 dB / octave
<b>Linearity Error</b>	0.1% FSO maximum
<b>Stability</b>	0.1% FSO maximum
<b>Accuracy vs. Temperature</b>	±0.0065% / °C (65ppm / °C)
<b>Maximum Inaccuracy of Output</b>	0.05% @ 25°C, FSO maximum 0.3% @ 0-60°C, FSO maximum
<b>Isolation</b>	1500 VDC Input - Output
<b>Operating Temperature</b>	0-60°C (32 to 140°F)
<b>Storage Temperature</b>	-20 to 70°C (-4 to 158°F)
<b>Relative Humidity</b>	5 to 90% (non-condensing)
<b>Vibration</b>	ML STD 810C 514.2
<b>Shock</b>	ML STD 810C 516.2
<b>Noise Immunity</b>	NEMA ICS3-304

### NOTES:

1. When adjusting SPAN and OFFSET potentiometer
2. Voltage required to power internal circuitry
3. Formula,  $[(\text{output load}) \times 20 \text{ mA}] + 8.5 \text{ V}$ , i.e. 13.5 VDC @ 250 Ω
4. Internal analog converter resolution is 12-bit

### Typical User Wiring

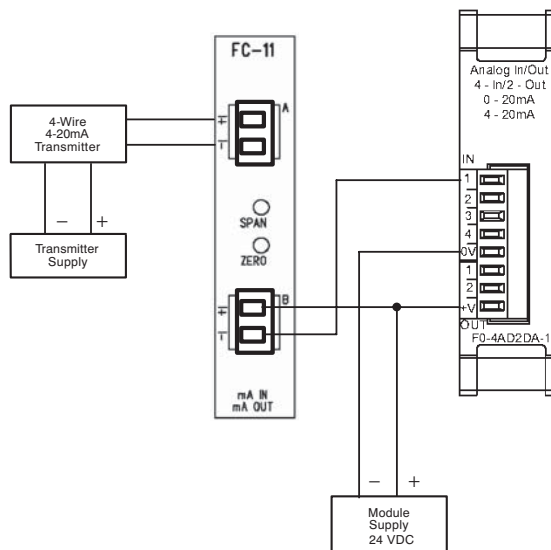

4-20 mA Input Isolated to 4-20 mA Output (example)

See page 22-13 for signal conditioner dimensions.

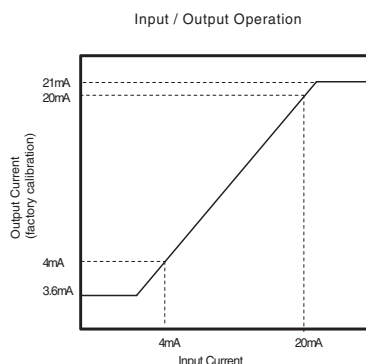

- PLC Overview
- DL05/06 PLC
- DL105 PLC
- DL205 PLC
- DL305 PLC
- DL405 PLC
- Field I/O
- Software
- C-more HMIs
- Other HMI
- AC Drives
- Motors
- Steppers/Servos
- Motor Controls
- Proximity Sensors
- Photo Sensors
- Limit Switches
- Encoders
- Pushbuttons/Lights
- Process
- Relays/Timers
- Comm.
- TB's & Wiring
- Power
- Enclosures
- Appendix
- Part Index

# FC-T1 Thermocouple/mV Input Isolated Signal Conditioner



## Overview

The FC-T1 is a DIN-rail or side-mount thermocouple/mV input signal conditioner with 1500 VAC isolation between input and output.

The field configurable input allows a wide ranging capability for a type J, K, E, R, S, T, B, N and C thermocouple, or 0-156.25 mV and  $\pm 156.25$  mV signals.

The FC-T1 has built-in self-calibration, but also offers OFFSET (zero) and SPAN (full scale) potentiometer for adjustment of the output signal.

The FC-T1 is also equipped with cold junction compensation (CJC) circuitry to provide an internal ice-point reference.

The temperature calculation and linearization are based on data provided by the National Institute of Standards and Technology (NIST).

**ALARM and RUN LED:** This LED is bicolor (red and green). A red LED indicates either power up, a fault with internal calibration, or a thermocouple burnout condition, while a green LED indicates normal operation.

**Burnout Function:** The output current can be selected to provide either upscale (20 mA) or downscale (4 mA) detection whenever thermocouple burnout occurs.

Specifications				
<b>Input Ranges</b>	<b>T/C</b>	<b>°C</b>	<b>°F</b>	<b>Resolution<sup>1</sup></b>
	J	-190 to 760	-310 to 1400	0.23°C
	K	-150 to 1372	-238 to 2502	0.37°C
	E	-210 to 1000	-345 to 1832	0.295°C
	R	65 to 1768	149 to 3214	0.42°C
	S	65 to 1768	149 to 3214	0.42°C
	T	-230 to 400	-382 to 752	0.15°C
	B	529 to 1820	984 to 3308	0.315°C
	N	-70 to 1300	-94 to 2372	0.33°C
	C	65 to 2320	149 to 4208	0.55°C
	0 to 156.25 mV			0.038 mV
	-156.25 mV to +156.25 mV			0.076 mV
<b>Output Range</b>	4 to 20 mA			
<b>External Power Supply</b>	15 mA, 22 to 26 VDC			
<b>Input Impedance</b>	>5 MΩ			
<b>Absolute Maximum Rating</b>	Fault protected input $\pm 50$ V			
<b>Maximum Inaccuracy</b>	$\pm 3^\circ\text{C}$ , Temperature Input $\pm 0.01\%$ , Voltage Input			
<b>Linearity Error</b>	0.1%			
<b>Over Temperature Error</b>	0.1 X 10 <sup>-5</sup> % (10 ppm)/°C			
<b>Insulation Resistance</b>	$\geq 100$ M $\Omega$ with 500 VDC (Input to output power)			
<b>Isolation</b>	1500 VAC @ 1 Sec. (Input to output commons)			
<b>Sample Duration Time</b>	120 mS Voltage Input 250 mS Thermocouple Input			
<b>Common Mode Rejection</b>	-100 dB @ DC, -90 dB @ 50/60 Hz			
<b>Input Filter (FIR)</b>	-3 dB @ 15 Hz, -100 dB @ 50 Hz, -100 dB @ 60 Hz			
<b>Broken Thermocouple</b>	Up/Down Scale Red/Green LED			
<b>Over Range</b>	Up Scale			
<b>Under Range</b>	Down Scale			
<b>Burnout Time</b>	$\leq 3$ Seconds			
<b>Cold Junction Compensation</b>	Automatic			
<b>Warm-up Time</b>	30 min. typical $\pm 1^\circ\text{C}$ repeatability			
<b>Operating Temperature</b>	0 to 60°C (32 to 140°F)			
<b>Storage Temperature</b>	-20 to 70°C (-4 to 158°F)			
<b>Relative Humidity</b>	5 to 90% (non-condensing)			
<b>Environmental Air</b>	No corrosive gases permitted			
<b>Vibration</b>	ML STD 810C 514.2			
<b>Shock</b>	ML STD 810C 516.2			
<b>Noise Immunity</b>	NEMA ICS3-304			

Note:

<sup>1</sup> Internal analog converter resolution is 12-bit.

# FC-T1 Thermocouple/mV Input Isolated Signal Conditioner

## Application

The FC-T1, field configurable thermocouple/mV signal conditioner, is useful in eliminating ground loops and for interfacing to PLC analog input modules. If your requirements are only for one channel of temperature, you can add the signal conditioner to your 4-20 mA input module. Or, if your requirements are for a single millivolt signal source, you have the option of adding this input to your analog module.

### Typical User Wiring

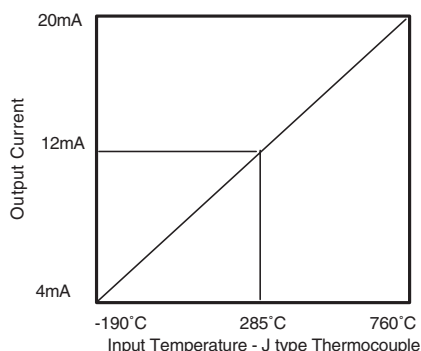
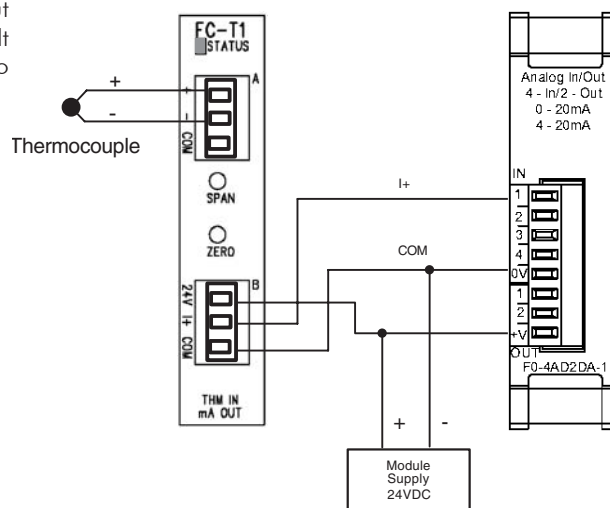

## Signal Conditioner Dimensions

These dimensions are typical for all of the signal conditioners. All dimensions are in inches (millimeters).

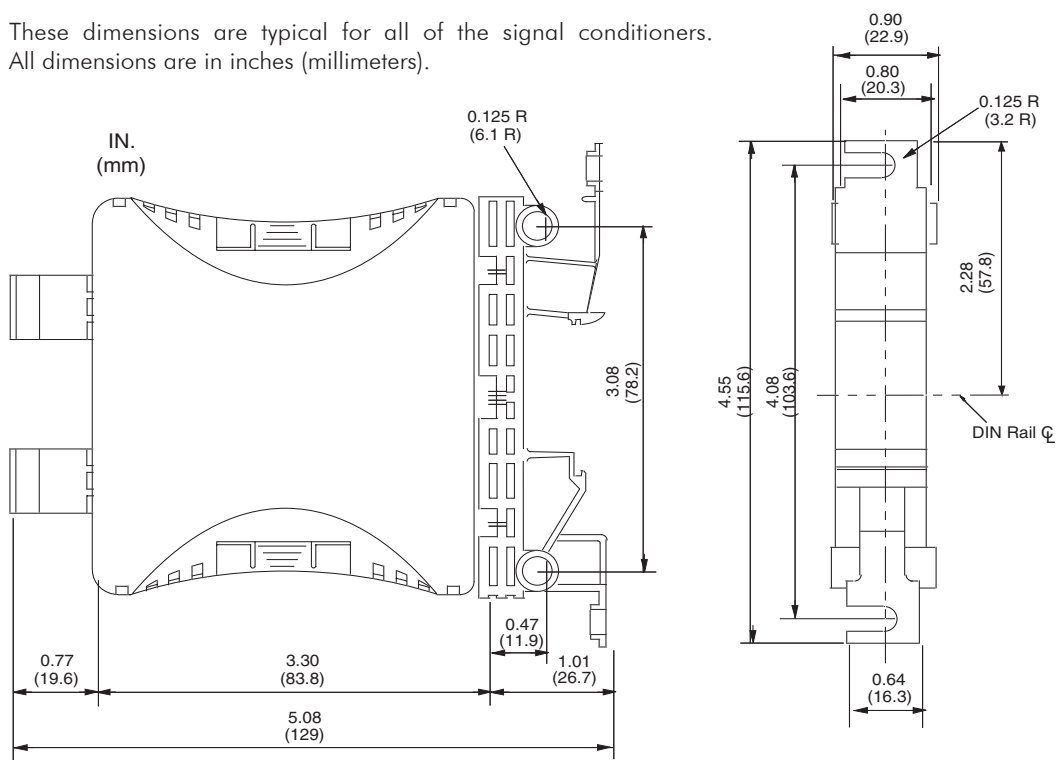

- PLC Overview
- DL05/06 PLC
- DL105 PLC
- DL205 PLC
- DL305 PLC
- DL405 PLC
- Field I/O
- Software
- C-more HMIs
- Other HMI
- AC Drives
- Motors
- Steppers/Servos
- Motor Controls
- Proximity Sensors
- Photo Sensors
- Limit Switches
- Encoders
- Pushbuttons/Lights
- Process
- Relays/Timers
- Comm.
- TB's & Wiring
- Power
- Enclosures
- Appendix
- Part Index

# FC-R1 RTD Input Loop Powered Signal Conditioner



## Overview

The FC-R1 is a DIN-rail or side-mount Resistive Temperature Detector signal conditioner. It is a non-isolated signal conditioner which converts a 3-wire RTD to a linearized 4-20 mA current loop signal.

The FC-R1 has a user selectable CU10 (10 Ohm copper), PT100 (100 Ohm platinum) or PT1000 (1000 Ohm platinum) RTD input, and also offers OFFSET (zero) and SPAN (full scale) adjustments of the output signal. The OFFSET has an adjustment range of 0 to 25% of full scale output and the SPAN has an adjustment of 80% to 102%.

Specifications			
<b>Input Ranges</b>	CU10	-200°C to 260°C	-328°F to 500°F
	PT100	-200°C to 850°C	-328°F to 1562°F
	PT1000	-200°C to 595°C	-328°F to 1103°F
<b>RTD Excitation Current</b>	CU10, PT100 500 $\mu$ A $\pm$ 50 $\mu$ A PT1000 80 $\mu$ A $\pm$ 20 $\mu$ A		
<b>Common Mode Range</b>	0 - 3.5 VDC		
<b>Output Range</b>	4-20 mA (linearized)		
<b>Maximum Inaccuracy</b>	0.35% FSO / CU10 0.2% FSO @ 25°C / PT100 & PT1000 0.26% FSO @ 60°C / PT100 & PT1000		
<b>Maximum Loop Supply</b>	30 VDC		
<b>Load Impedance</b>	0 $\Omega$ minimum		
<b>Maximum Load/Power Supply</b>	203 $\Omega$ / 12 V, 745 $\Omega$ / 24 V		
<b>Linearity Error</b>	0.35% FSO / CU10 0.2% FSO / PT101 & PT1000		
<b>Output Slew Rate</b>	1% @ 20 mS		
<b>Filter Characteristics</b>	105 dB @ DC, 60 dB @ 10 Hz, 40 dB @ 60Hz		
<b>Stability</b>	0.05% FSO maximum		
<b>Operating Temperature</b>	0 to 60°C (32 to 140°F)		
<b>Storage Temperature</b>	-20 to 70°C (-4 to 158°F)		
<b>Relative Humidity</b>	5 to 90% (non-condensing)		
<b>Environmental Air</b>	No corrosive gases permitted		
<b>Vibration</b>	ML STD 810C 514.2		
<b>Shock</b>	ML STD 810C 516.2		
<b>Noise Immunity</b>	NEMA ICS3-304		

See page 22-13 for signal conditioner dimensions.

## Application

The FC-R1 field configurable input signal conditioner is useful for interfacing RTD sensors to PLC analog current input modules. It is recommended that shielded RTD's be used whenever possible to minimize noise on the input signal.

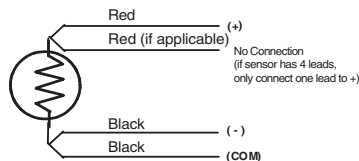
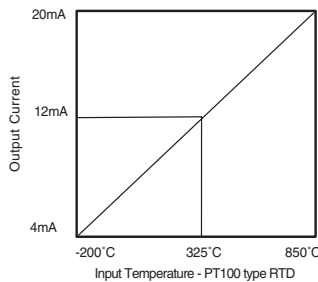

## Typical User Wiring

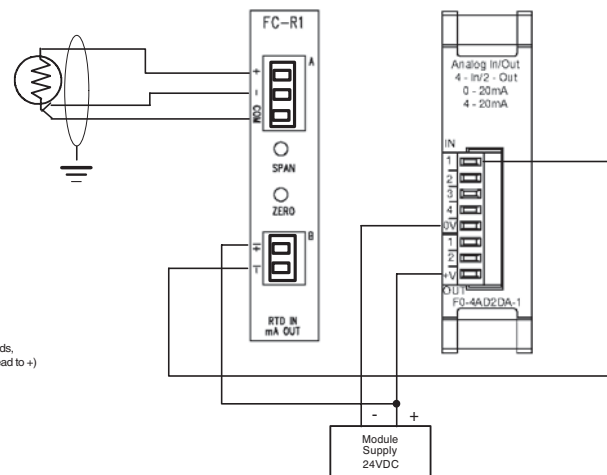

RTD Signal Conditioner to 4-20 mA DL05/06 analog module  
Only use three wire and four wire RTDs.