

Analog In/Out Combination Module

NOT SUPPORTED IN D2-230 AND D2-240 CPUs.

F2-8AD4DA-1 8-Channel Analog Current Input / 4-Channel Analog Current Output	
Input Channels per Module	8, single ended (one common)
Input Range	0 to 20 mA
Resolution	12, 14, 16-bit selectable
External DC Power Required	100 mA @ 18-26.4 VDC
Max. Continuous Overload	±45 mA
Input Impedance	100 Ω 0.1% 1/4W
Filter Characteristics	Active low pass, -3dB @ 80 Hz
Conversion Time	12-bit = 1.5 ms per channel 14-bit = 6 ms per channel 16-bit = 25 ms per channel
Conversion Method	Over sampling successive approximation
Accuracy vs. Temperature	±25 ppm / °C Max.
Maximum Inaccuracy	0.1% of range
Linearity Error (End to End)	12-bit = ±2 count max. (±0.06% of range) 14-bit = ±10 count max. (±0.06% of range) 16-bit = ±20 count max. (±0.06% of range) Monotonic with no missing codes
Full Scale Calibration Error (not including offset error)	±0.07% of range max.
Offset Calibration Error	±0.03% of range max.
Rec. Fuse (external)	0.032A, Littelfuse Series 217 fast-acting
Base Power Required 5VDC	35 mA

Output Channels per Module	4
Output Range	4 to 20 mA
Resolution	16-bit, 0.244 mA/bit
Output Type	Current sourcing at 20 mA max.
Load Impedance	0-750 Ω
Max. Inaccuracy	0.25% of range
Max. Full Scale Calibration Error (not incl. offset error)	±0.175% of range max.
Max. Offset Calibration Error	±0.1% of range max.
Accuracy vs. Temperature	±25 ppm/ °C max. full scale calibration change (± 0.0025% of range / °C)
Max. Crosstalk at DC, 50/60Hz	-70 dB, 1 LSB
Linearity Error (End to End)	±1 count max. (±0.025% of full scale) Monotonic with no missing codes
Output Stability and Repeatability	±1 LSB after 10 min. warm-up typical
Output Ripple	0.005% of full scale
Output Settling Time	0.5 ms max., 5 μs min. (full scale change)
Max. Continuous Overload	Outputs open circuit protected
Type of Output Protection	Electronically current limited to 20 mA or less
Output Signal at Power-up and Power-down	4 mA
Terminal Type (included)	Removable; D2-16IOCON

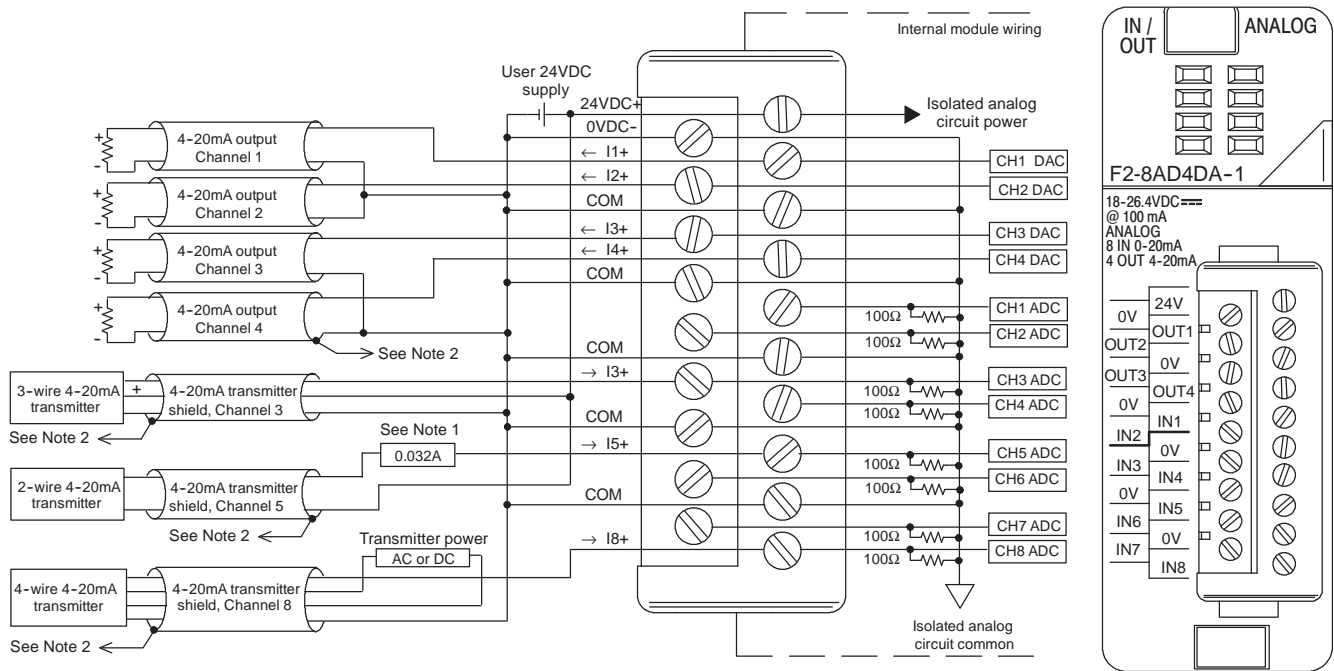

Note 1: A Littelfuse Series 217, 0.032A fast-acting fuse is recommended for all 4-20mA current loop inputs.
 Note 2: Connect shields to the 0V of the module; do not connect both ends of shield.