

Analog Current Input Modules

F2-04AD-1 4-Channel 4-20mA Analog In

This module requires a 24 VDC user power supply for operation. See the F2-04AD-1L on the next page if you want to use a 12 VDC supply. All other specifications are the same.

Number of Channels	4, single ended (1 common)
Input Ranges	4 to 20 mA current
Resolution	12-bit (1 in 4096)
Active Low-pass Filtering	-3 dB at 80 Hz, 2 poles (-12 dB per octave)
Input Impedance	250Ω ±0.1%, 1/2W current input
Absolute Maximum Ratings	-40 mA to +40 mA, current input
Converter Type	Successive approximation
Conversion Time (PLC Update Rate)	1 channel per scan maximum (D230 CPU); 4 channels per scan maximum (D2-240, D2-250(-1) and D2-260 CPUs)
Linearity Error (End to End)	±1 count (0.025% of full scale) maximum
Input Stability	±1 count
Full Scale Calibration Error (offset error not included)	±12 counts max., @ 20 mA current input
Offset Calibration Error	±7 counts max., @ 4mA current input
Step Response	4ms to 95% of F.S. change

Maximum Inaccuracy	±.5% @ 77°F (25°C) ±.65% 32° to 140°F (0° to 60°C)
Accuracy vs. Temperature	±50 ppm/°C maximum full scale (including max. offset change)
Recommended Fuse	0.032 A, Series 217 fast-acting, current inputs
Digital Input Points Required	16 (X) input points (12 binary data bits, 2 channel ID bits, 2 diagnostic bits)
Base Power Required 5 VDC	50 mA
External Power Supply	80 mA maximum, +18 to +30 VDC
Operating Temperature	32° to 140°F (0° to 60°C)
Storage Temperature	-4° to 158°F (-20° to 70°C)
Relative Humidity	5 to 95% (non-condensing)
Environmental Air	No corrosive gases permitted
Vibration	MIL STD 810C 514.2
Shock	MIL STD 810C 516.2
Noise Immunity	NEMA ICS3-304
Terminal Type (included)	Removable; D2-8IOCON

One count in the specification table is equal to one least significant bit of the analog data value (1 in 4096).

Note 1: Shields should be grounded at the signal source

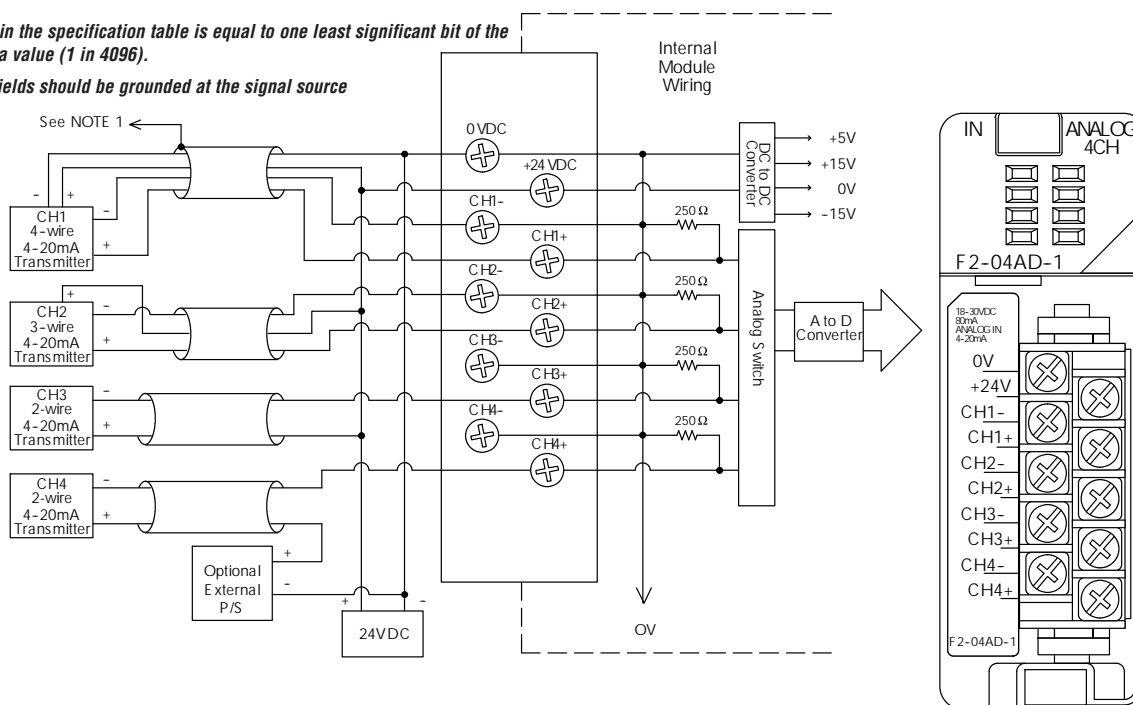

More than one external power supply can be used provided all the power supply commons are connected. A Series 217, 0.032A, fast-acting fuse is recommended for 4-20 mA current loops. If the power supply common of an external power supply is not connected to 0VDC on the module, then the output of the external transmitter must be isolated. To avoid "ground loop" errors, recommended 4-20 mA transmitter types are:

2 or 3 wire: Isolation between input signal and power supply.

4 wire: Isolation between input signal, power supply, and 4-20 mA output