

# Analog Current Output Modules

F2-02DA-1 2-Channel 4-20 mA Analog Output	
This module requires a 24 VDC user power supply for operation. See the F2-02DA-1L on the next page if you want to use a 12 VDC supply. All other specifications are the same.	
<b>Number of Channels</b>	2
<b>Output Ranges</b>	4 to 20 mA
<b>Resolution</b>	12 bit (1 in 4096)
<b>Output Type</b>	Single ended, one common
<b>Digital Output Points Required</b>	16 (Y) output points (12 binary data bits, 2 channel ID bits)
<b>Maximum Loop Supply</b>	30 VDC
<b>Peak Output Voltage</b>	40 VDC (clamped by transient voltage suppressor)
<b>Load Impedance</b>	0Ω minimum
<b>Maximum Load/Power Supply</b>	620 Ω/18 V, 910 Ω/24 V, 1200 Ω/ 30V
<b>PLC Update Rate</b>	1 channel per scan maximum D2-230 CPU 2 channels per scan maximum (D2-240, D2-250(-1) and D2-260 CPUs)
<b>Linearity Error (end to end)</b>	±1 count (±0.025% of full scale) maximum
<b>Conversion Settling Time</b>	100 μs maximum (full scale change)
<b>Full Scale Calibration Error (offset error included)</b>	± 5 counts max., 20 mA @77°F (25°C)
<b>Offset Calibration Error</b>	± 3 counts max., 4 mA @ 77°F (25°C)

<b>Accuracy vs. Temperature</b>	±50 ppm/°C full scale calibration change (including maximum offset change of 2 counts)
<b>Maximum Inaccuracy</b>	0.1% @ 77°F (25°C) 0.3% @ 32° to 140°F (0° to 60°C)
<b>Base Power Required 5VDC</b>	40 mA
<b>External Power Supply</b>	18 to 30 VDC, 60 mA. (add 20 mA for each current loop used)
<b>Operating Temperature</b>	32° to 140°F (0° to 60°C)
<b>Storage Temperature</b>	-4 to 158°F (-20 to 70°C)
<b>Relative Humidity</b>	5% to 95% (non-condensing)
<b>Environmental Air</b>	No corrosive gases permitted
<b>Vibration</b>	MIL STD 810C 514.2
<b>Shock</b>	MIL STD 810C 516.2
<b>Noise Immunity</b>	NEMA ICS3-304
<b>Terminal Type (included)</b>	Removable; D2-8IOCON

One count in the specification table is equal to one least significant bit of the analog data value (1 in 4096).

NOTE 1: Shields should be connected to the 0V of the module or the 0V of the R/S.  
NOTE 2: Unused current outputs should remain open (no connections) for minimum power consumption.

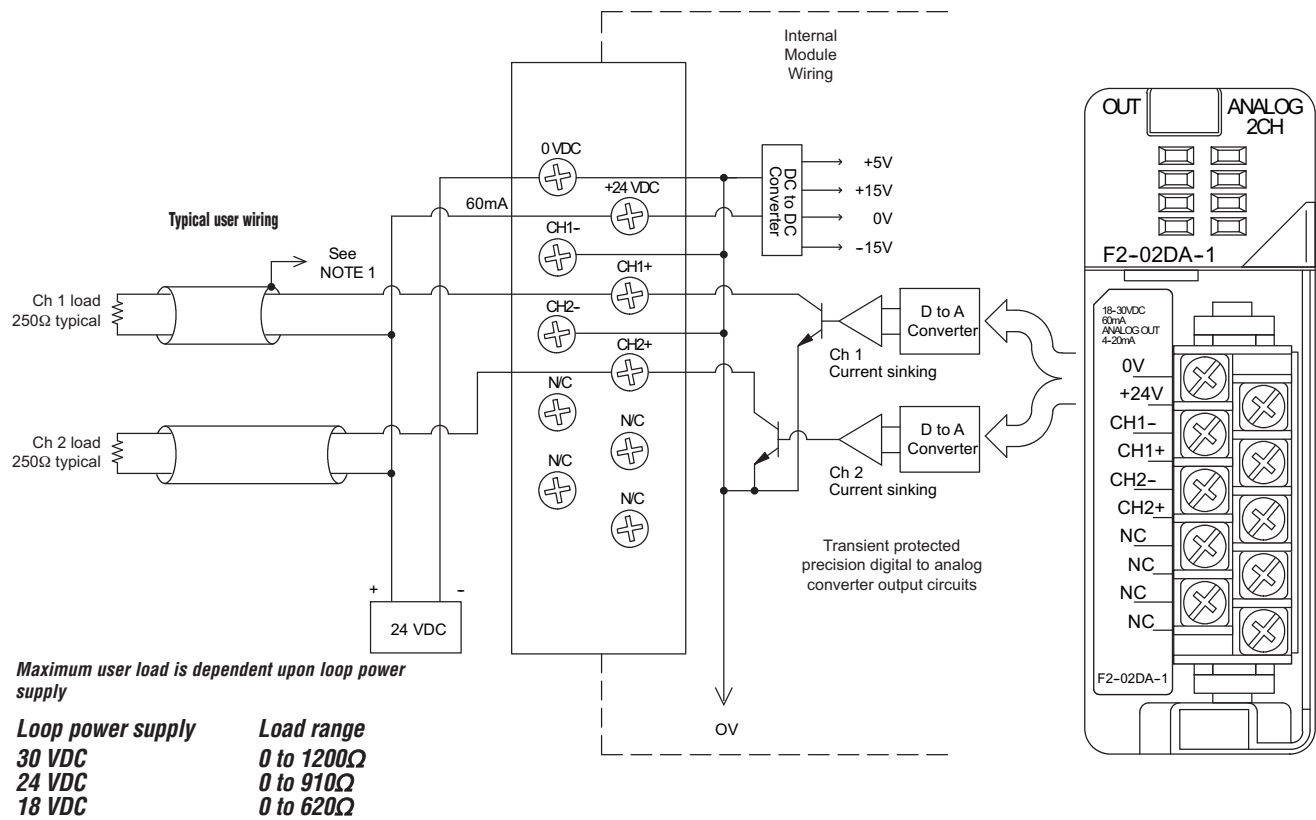

- PLC Overview
- DL05/06 PLC
- DL105 PLC
- DL205 PLC**
- DL305 PLC
- DL405 PLC
- Field I/O
- Software
- C-more HMIs
- Other HMI
- AC Drives
- Motors
- Steppers/Servos
- Motor Controls
- Proximity Sensors
- Photo Sensors
- Limit Switches
- Encoders
- Current Sensors
- Pushbuttons/Lights
- Process
- Relays/Timers
- Comm.
- TB's & Wiring
- Power
- Circuit Protection
- Enclosures
- Appendix
- Part Index