

GS series and DURAPULSE AC Drives

Section 12



Hitachi AC Drives

Section 13



Marathon Motors

Section 14



Steppers and Servos

Section 15



Table of Contents

Drives and Motors Overview	12-2
GS1 and GS2 Series AC Drives	12-4
DURApulse AC Drives Overview	12-6
AC Drives Communications	12-8
GSoft Configuration Software	12-8
Ethernet Connectivity	12-9
3 Steps to Selecting the Right AC Drive ..	12-10

GS1 Series	12-14
GS1 Series Specifications	12-15
GS1 Installation	12-17
GS1 Terminals	12-18
GS1 Basic Wiring Diagram	12-19
GS1 Dimensions	12-20

GS2 Series	12-22
GS2 Series Specifications	12-23
GS2 Installation	12-28
GS2 Terminals	12-29
GS2 Basic Wiring Diagram	12-30
GS2 Dimensions	12-31

DURApulse AC Drives	12-32
DURApulse Specifications	12-33
DURApulse Installation	12-35
DURApulse Terminals	12-36
DURApulse Basic Wiring Diagram	12-37
DURApulse Dimensions	12-42

GS/DURApulse Accessories Overview ..	12-46
DURApulse GS3-FB Card	12-48
DURApulse Line Reactors	12-50
DURApulse Braking Units	12-54
DURApulse Braking Resistors	12-56
DURApulse EMI Filters	12-61
DURApulse RF Filters	12-67
DURApulse Fuse Kits	12-68
DURApulse Ethernet Interface	12-71
DURApulse Software	12-72

Hitachi SJ300 Flux Vector Drives	13-1
---	-------------

Marathon Electric Motors	14-1
---------------------------------------	-------------

Stepper and Servo Systems	15-1
--	-------------

GS1 and GS2 Series AC Drives



Simple communications
 Each drive has a built-in Modbus RTU RS-485 communications port (RS-232/485 configurable on the GS2 series). An optional Ethernet communications module is a snap to integrate on a network with our PLCs and operator interfaces.

GS1 AC minidrive

1/4 and 1/2 hp, 115 VAC single phase
 1/4, 1/2 and 1 hp, 115/230 VAC single phase/3-phase
 2 hp, 230 VAC 3-phase

Features:

- Simple Volts/Hertz control
- Pulse Width Modulation(PWM)
- 3 - 10 kHz carrier frequency
- IGBT technology
- 130% starting torque at 5 Hz
- 130% rated current for 1 minute
- Electronic overload protection and stall prevention
- Adjustable accel and decel ramps
- S-curve settings for acceleration and deceleration
- Automatic torque and slip compensation
- DC braking
- Three skip frequencies
- Trip history
- Integral keypad and speed potentiometer
- Programmable jog speed
- Three programmable preset speeds
- Four programmable digital inputs, one programmable relay output
- Programmable analog input
- RS-485 Modbus communications up to 19.2K
- Optional Ethernet communications
- UL/CUL listed; CE

High-quality AC drives
 The GS series is manufactured exclusively for **AutomationDirect** with reliable IGBT technology. We started with a proven design and made it even better and easier to use.

Removable keypad
 The removable keypad includes an LED display for parameters and data, programming keys and a potentiometer for direct setpoint adjustment. The keypad can be remotely mounted (with optional keypad cable).



GS1 Mini AC Inverters

Part Number	Input Voltage	Output Voltage	hp	Output Amps
GS1-10P2	115V, 1ph	230V, 3ph	0.25	1.6 A
GS1-10P5	115V, 1ph	230V, 3ph	0.5	2.5 A
GS1-20P2	230V, 1ph/3ph	230V, 3ph	0.25	1.6 A
GS1-20P5	230V, 1ph/3ph	230V, 3ph	0.5	2.5 A
GS1-21P0	230V, 1ph/3ph	230V, 3ph	1.0	4.2 A
GS1-22P0	230V, 3ph	230V, 3ph	2.0	7.0 A

GS2 Micro AC Inverters

Part Number	Input Voltage	Output Voltage	hp	Output Amps
GS2-10P2	115V, 1ph/3ph	230V, 3ph	0.25	1.6
GS2-10P5	115V, 1ph/3ph	230V, 3ph	0.5	2.5
GS2-11P0	115V, 1ph/3ph	230V, 3ph	1.0	4.2
GS2-20P5	230V, 1ph/3ph	230V, 3ph	0.5	2.5
GS2-21P0	230V, 1ph/3ph	230V, 3ph	1.0	5.0
GS2-22P0	230V, 1ph/3ph	230V, 3ph	2.0	7.0
GS2-23P0	230V, 1ph/3ph	230V, 3ph	3.0	10.0
GS2-25P0	230V, 3ph	230V, 3ph	5.0	17.0
GS2-27P5	230V, 3ph	230V, 3ph	7.5	25.0
GS2-41P0	460V, 3ph	460V, 3ph	1.0	3.0
GS2-42P0	460V, 3ph	460V, 3ph	2.0	4.0
GS2-43P0	460V, 3ph	460V, 3ph	3.0	5.0
GS2-45P0	460V, 3ph	460V, 3ph	5.0	8.2
GS2-47P5	460V, 3ph	460V, 3ph	7.5	13.0
GS2-4010	460V, 3ph	460V, 3ph	10	18.0
GS2-51P0	575V, 3ph	575V, 3ph	1	1.7
GS2-52P0	575V, 3ph	575V, 3ph	2	3.0
GS2-53P0	575V, 3ph	575V, 3ph	3	4.2
GS2-55P0	575V, 3ph	575V, 3ph	5	6.6
GS2-57P5	575V, 3ph	575V, 3ph	7.5	9.9
GS2-5010	575V, 3ph	575V, 3ph	10	12.2

Simple to Install, Simple to Configure



Simple programming

The GS series can be programmed by the average technician. Default values were carefully selected so the drives run “out of the box” for most applications. Parameters are intelligently grouped into menu structures that make sense.

Two-year warranty

The standard two-year warranty for the GS series is the best in the industry.

GS2 AC microdrive

½ hp to 7.5 hp, 230 VAC

1 to 10 hp, 460 VAC

1 to 10 hp, 575 VAC **(NEW!)**

Features:

- All GS1 features, plus:
- 1-12 kHz carrier frequency
- 150% starting torque
- Dynamic braking circuit
- Seven programmable preset speeds
- Integral PID control
- Removable keypad with potentiometer
- Programmable analog input and output
- Six programmable digital inputs, two programmable relay outputs
- RS-232/485 Modbus communications up to 38.4K
- UL/CUL listed; CE

PLC Overview

DL05/06 PLC

DL105 PLC

DL205 PLC

DL305 PLC

DL405 PLC

Field I/O

Software

C-more HMIs

Other HMI

AC Drives

Motors

Steppers/ Servos

Motor Controls

Proximity Sensors

Photo Sensors

Limit Switches

Encoders

Pushbuttons/ Lights

Process

Relays/ Timers

Comm.

TB's & Wiring

Power

Enclosures

Appendix

Part Index

DURAPULSE AC Drives

DURAPULSE builds on the GS series

The *DURAPULSE* series builds on the simplicity and flexibility of the GS1 and GS2 series, incorporating feedback from our customers and extensive research and testing in our own drives lab. While the GS1 offers simple Volts per Hertz control, and the GS2 adds PID functionality and dynamic braking, *DURAPULSE* offers sensorless vector control and autotuning, as well as optional encoder feedback for enhanced speed control. *DURAPULSE* configuration settings are a superset of the GS series, so programming for the same parameters is identical across all series.



DURA PULSE

Visit: www.durapulse.com

Durability guaranteed

DURAPULSE drives are backed by the same 2-year warranty as the GS series!

Features

- Simple Volts/Hertz control
- Sensorless vector control with autotune
- Sensorless vector control with optional encoder feedback card, for tighter speed control
- Variable carrier frequency, depending on model
- IGBT technology
- 150% starting torque
- 150% rated current for one minute
- Internal dynamic braking circuit for models under 20 hp
- Automatic torque and slip compensation
- Programmable jog speed
- Removable smart keypad with parameter upload/download
- Easy-to-understand parameter text labels
- HIM keypad with memory to store up to four programs of any DURApulse drive
- Three analog inputs and one analog output
- Eleven digital inputs
- Four programmable outputs: Three digital and one relay
- One digital frequency pulse output
- RS-485 Modbus communications
- Ethernet communication optional
- UL/CE listed
- Optional software package with full programmability, trending and application setup

Little programming required

Default values were carefully selected so the drives run "out of the box" for most applications, with default values set for the U.S. industrial market. Keypad can store up to 4 configuration programs for any *DURAPULSE* drive. Great for maintenance backup and OEM programming ease.

U.S. operating parameters

DURAPULSE drives are specifically designed to operate with U.S. voltage levels.

Encoder feedback

Optional encoder feedback module allows additional control routine for speed control



Sensorless Vector Technology up to 100 hp

DURAPULSE AC Inverters

Hp	Part Number	Output Amps	Part Number	Output Amps	
1.0	GS3-21P0	5	GS3-41P0	2.7	
2.0	GS3-22P0	7	GS3-42P0	4.2	
3.0	GS3-23P0	11	GS3-43P0	5.5	
5.0	GS3-25P0	17	GS3-45P0	8.5	
7.5	GS3-27P5	25	GS3-47P5	13	
10	GS3-2010	33	GS3-4010	18	
15	GS3-2015	49	GS3-4015	24	
20	GS3-2020	65	GS3-4020	32	
25	GS3-2025	75	GS3-4025	38	
30	GS3-2030	90	GS3-4030	45	
40	GS3-2040	120	GS3-4040	60	
50	GS3-2050	145	GS3-4050	73	
60	n/a	n/a	n/a	GS3-4060	91
75	n/a	n/a	n/a	GS3-4075	110
100	n/a	n/a	n/a	GS3-4100	150

Accessories

- AC line reactors
- EMI filters
- Braking resistors
- Fuse kits and replacement fuses
- RF filter
- GS3-FB feedback card
- Ethernet interface
- GSoft drive configuration software
- Replacement keypads
- Remote panel adapter
- Keypad cables in 1, 3 and 5 meter lengths
- Four and eight-port communication boards

LCD Display

LCD display for real language programming. No need to have a manual to understand parameter configuration.

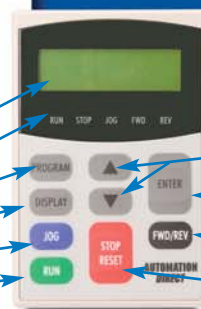

The lit LED Indicators will blink when there is a Fault or a Warning.

- LCD Display
- LED Indicators
- Program Key
- Display Key
- Jog Key
- Run Key
- Up/Down Keys
- Enter Key
- Fwd/Rev Key
- Stop/Reset Key

Remote mounting of keypad

Standard keypad mounted on unit's face can also be remote mounted for easy access to data and parameters. Requires remote cable.



The DURAPULSE Digital Keypad

The digital keypad includes a 2 line x 16 character LCD display, 5 status LED Indicators, and 9 function keys. The diagram to the right shows all of the features of the digital keypad and an overview of their functions.

The standard smart keypad (aka HIM or Human Interface Module) is designed with defaults for the North American customer and allows you to configure the drive, set the speed, start and stop the drive, and monitor critical parameters for your application. In addition, this keypad has internal memory that allows four complete programs to be stored and transferred to any DURAPULSE drive.

GSoft Configuration Software

GSoft configuration software, available for \$50.00, is a Windows-based package that allows connection from a PC to any GS or *DURAPULSE* drive for easy configuration and tuning. You can create new drive configurations, upload and download archived configurations, and tune the drive's PID loop with intuitive screens.

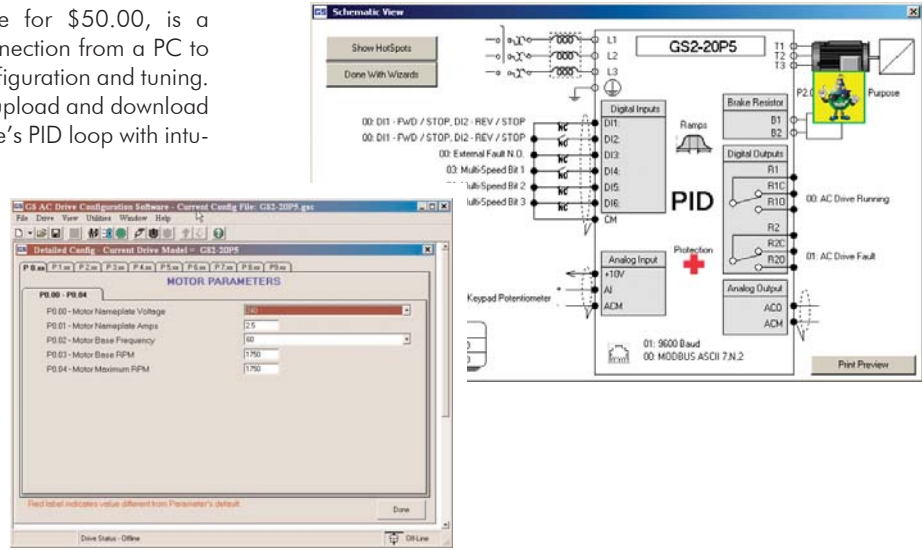

Networking AC Drives with Built-in Modbus Communications

AUTOMATIONDIRECT's AC drives offer "out-of-the-box" RS-485 and RS-232 (GS2 series only) serial connectivity. Modbus RTU is the onboard standard protocol used for control and monitoring. This can be used to connect several Modbus masters like AUTOMATIONDIRECT's family of *Direct*LOGIC PLCs, Think & Do Studio or Live!, and any OPC server that has a Modbus driver such as Kepware or Software Toolbox.

Imagine getting all the parameter settings and control functionality on one cable, even when the information is not readily available by any other means. This flexibility offers cost savings, standardization, smaller PLC usage, and less development time.



RS-485 Modbus Network

Add Ethernet Connectivity for Advanced Functionality

Add Ethernet connectivity and open up the path to the most advanced functionality today.

The GS-EDRV provides a high-performance Ethernet link between a control system and a **DURAPULSE** or GS drive. It mounts on DIN rail and connects a drive to an Ethernet hub or PC. The GS-EDRV processes signals to and from the drive and formats them to conform with the Ethernet standard to the H2-ERM or H4-ERM, **KEPDirect** EBC I/O server (as shown below), or independent controller with the Modbus TCP/IP driver. This allows for greater connectivity to many control system architectures.

An additional feature is the built-in Web server, which allows users to configure and control the drive from any web browser via the IP address of the GS-EDRV card. The **DURAPULSE** and GS series drives have a provision for shutting down control or power to the inverter in the event of a communications timeout. This function can be set up through the drive parameter group 9 on all the drive platforms.

The **KEPDirect** EBC I/O server software is a 32-bit application that provides a way to connect your favorite Windows client software to **AUTOMATIONDIRECT** Ethernet I/O through our Ethernet base controllers. It provides GS series drive support via the GS-EDRV Ethernet interface, as shown in the diagram below. **KEPDirect** allows the user a direct line into the drive parameter group just like an Ethernet field I/O drop. The user can control or monitor from any OPC/DDE compliant third party software. For a complete description of **KEPDirect** software features, go to the Software section of this catalog. Several application notes specific to the versatility of this software can be found on our web site at www.automationdirect.com.



PLC Overview

DL05/06 PLC

DL105 PLC

DL205 PLC

DL305 PLC

DL405 PLC

Field I/O

Software

C-more HMI's

Other HMI

AC Drives

Motors

Steppers/ Servos

Motor Controls

Proximity Sensors

Photo Sensors

Limit Switches

Encoders

Pushbuttons/ Lights

Process

Relays/ Timers

Comm.

TB's & Wiring

Power

Enclosures

Appendix

Part Index

3 Steps to Selecting the Right AC Drive



STEP 1 - Select The Right Model

A. Determine motor voltage, horsepower and full-load amperage

	AC drive models			
	GS1	GS2	DURAPULSE	SJ300
Horsepower	1/4 - 2	1/4 - 10*	1 - 100**	1/2 - 30
Input voltage	115/230 VAC	115/230/460 VAC	230/460 VAC	230/460 VAC
Motor voltage	230 VAC	230/460 VAC	230/460 VAC	230/460 VAC

* 230V up to 7.5 hp
460V up to 10 hp
575V up to 10 hp

** 230V up to 50 hp
460V up to 100 hp

Check the nameplate on the motor for specs needed:

Motor horsepower →

Motor voltage →

Motor amperage →

Inverter Duty Motor							
HP	1	Volts	460	PHASE	3	TYPE	P
RPM	1725	AMPS	2.6	HZ	60	SF	1.15
DESIGN	B	AMB	40°C	INSUL CLASS	F		
DUTY	CONT	ENCL	TEFC	CODE	K		

Motor voltage, horsepower, and amperage can be found on the motor's nameplate.

Note: Most motors can be connected for multiple voltages and will have multiple amperages listed.

In the example to the left the motor can be connected for 460V only. The 460V amperage is 2.6.

B. Select your application and/or control mode

	AC Drive Models			
	GS1	GS2	DURAPULSE	SJ300
Volts/Hertz Control	✓	✓	✓	✓
Sensorless Vector Control		✓	✓	✓
Closed Loop Control			Optional	Optional
Encoder Feedback			Optional	Optional
Integral PID Control		✓	✓	✓
Integral Dynamic Braking Unit		✓	15 HP*	15 HP*
Conveyor	Conveyor	Conveyor	Conveyor	Conveyor
Pump	Pump	Pump	Pump	Pump
Fan	Fan	Fan	Fan	Fan
Shop tools	Shop tools	Shop tools	Shop tools	Shop tools
Material handling	Material handling	Material handling	Material handling	Material handling
HVAC	HVAC	HVAC	HVAC	HVAC
Mixing	Mixing	Mixing	Mixing	Mixing
Compressor	Compressor	Compressor	Compressor	Compressor
Shop tools	Shop tools	Shop tools	Shop tools	Shop tools
Extruding				Extruding
Grinders				Grinders
Web handling				Web handling
Spindle				Spindle

	Control Mode		
	Volts/Hertz	Sensorless Vector	Closed-Loop Control
Complexity	Low	Moderate	Complex
Performance	Good	Good	High
1 min. Overload	150%	150%	150%
Starting Torque	175%	200%	200%
Speed Regulation	+/- 2%	+/- 1%	+/- 0.2%

*15 hp requires external braking units

Either choose your application from those listed or select the control mode that meets your application's requirements. For applications not listed, either select the control mode that offers the same or higher level of performance as the existing control, or call us and ask for assistance.

C. Determine the I/O requirements of the AC drive

	AC Drive Models			
	GS1	GS2	DURAPULSE	SJ300
Digital Inputs	4	6	11	8
Digital Outputs - Transistor	0	0	3	5
Digital Outputs - Relay	1	2	1	1
Digital Output - Frequency pulse			1	
Analog Input - 0-10VDC/4-20mA	1	1	3	2
Analog Output - 0 - 10 VDC	0	1	1	Optional

Digital inputs are used to interface the AC drive with devices such as pushbuttons, selector switches and PLC digital output modules, either DC or relay. These signals are typically used for functions such as Start/Stop, Forward/Reverse, External Fault, Preset Speed selection, Fault Reset, etc.

Digital outputs are typically used to connect the AC drive to devices such as pilot lights, alarms, auxiliary relays, solenoids,

and PLC digital input modules. Relay outputs are rated for both AC and DC voltages. Transistor outputs are rated for only DC voltages.

The analog input is used to interface the AC drive with an external 0-10 VDC or 4-20 mA signal. This signal can represent either a speed setpoint or if available, PID feedback.

D. Determine location of AC drive's keypad

Removable Keypad	AC Drive Models			
	GS1	GS2	DURAPULSE	SJ300
		✓	✓	✓

The keypad of the GS2, DURApulse and SJ300 are removable and can be remotely mounted. If the AC drive is installed in a location that the operator cannot easily access, its keypad could

be relocated to a more suitable location. Remote mounting would require the purchase of the appropriate cable. The DURApulse drives come with a remote, panel-mount bezel.

E. Determine communications requirements

MODBUS Communications Ethernet Communications	AC Drive Models			
	GS1	GS2	DURAPULSE	SJ300
	✓	✓	✓	Optional
	Optional	Optional	Optional	N/A

A serial communication interface can be used to connect the AC drive to other devices that have the capability to function as a master device. The master device can control the AC drive with this interface instead of using the digital and analog I/O. The master can also use this interface to monitor the status of various AC drive parameters, speed, current, fault status, etc.

The GS1, GS2 and DURApulse AC drives have a standard Modbus RS-485 interface. The SJ300 requires an optional SC-OPE31 interface for the Modbus interface.

The GS1, GS2, and DURApulse drives also have the optional capability to communicate through an Ethernet interface. Please refer to the technical section of each model to determine the required Ethernet interface adapter and compatible Ethernet devices.

F. Select the proper series

After you have selected the AC drive series that meets your requirements, you need to determine the correct rating. Turn the page and proceed to Step two.

- PLC Overview
- DL05/06 PLC
- DL105 PLC
- DL205 PLC
- DL305 PLC
- DL405 PLC
- Field I/O
- Software
- C-more HMI's
- Other HMI
- AC Drives**
- Motors
- Steppers/ Servos
- Motor Controls
- Proximity Sensors
- Photo Sensors
- Limit Switches
- Encoders
- Pushbuttons/ Lights
- Process
- Relays/ Timers
- Comm.
- TB's & Wiring
- Power
- Enclosures
- Appendix
- Part Index

STEP 2

STEP 2 - Select the Proper Rating

A. Determine motor full load amperage (FLA)

Motor FLA is located on the nameplate of the motor.

Note: FLA of motors that have been rewound may be higher than stated.

B. Determine overload requirements

Many applications experience temporary overload conditions due to starting requirements or impact loading. Most AC drives are designed to operate at 150% overload for 60 seconds. If the application requires an overload greater than 150% or longer than 60 seconds, the AC drive must be oversized. NOTE: Applications that require replacement of existing motor starters with AC drives may require up to 600% overload.

C. Installation altitude

AC drives rely upon the cooling properties of air for cooling. As the altitude increases, the air becomes less dense. This decrease in air density decreases the cooling properties of the air. Therefore, the AC drive must be oversized to compensate for the decrease in cooling. Most AC drives are designed to operate at 100% capacity up to altitudes of 1000 m. Above 1000 m, the AC drive must be derated.

D. Determine max enclosure internal temp

AC drives generate a significant amount of heat and will cause the internal temperature of an enclosure to exceed the rating of the AC drive, even when the ambient temperature is less than 104 degrees F (40 degrees C). Enclosure ventilation and/or cooling may be required to maintain a maximum internal temperature of 104 degrees F (40 degrees C) or less. Ambient temperature measurements/calculations should be made for the maximum expected temperature. (SJ300 AC drives may also require a reduction in carrier frequency.)

E. Calculate required output amperage

Use the chart below to calculate the required FLA of the AC drive. Select the rating that equals the motor's voltage and equals or exceeds the calculated amperage.

		Example 1	Example 2
		GS Series DURAPULSE	
		ENTER Motor FLA	
		6	8
Overload Derate (overload %)	If Overload is less than 150% and less than 60 seconds, Then ENTER 1		
	If Overload is greater than 150% and less than 60 seconds, Then ENTER (overload/150%)	1.333	
	If Overload is greater than 60 seconds, Then ENTER (overload/100%) Multiply FLA x overload entry (This entry is the overload result)	8	10.8
Altitude Derate (meters)	If Altitude is less than 1000m Then ENTER 1	1	
	If Altitude is more than 1000m and less than 3000m Then ENTER 1+ ((altitude-1000) x 0.0001) Multiply overload result x altitude entry (This entry is the altitude result)	8	10.91
Ambient Temperature (°Celsius)	If Max enclosure internal temperature (MEIT) is less than 40°C Then ENTER 1		1
	If 40°C < MEIT < 50°C and GS series AC drive up to 5 hp Then ENTER 1	1	
	If 40°C < MEIT < 50°C and GS Series >5 hp or DURAPULSE series AC drive Then ENTER 1.2		
Multiply altitude result x MEIT entry (This result is the required drive FLA)		8	10.91

STEP 3 - Options, Options, and more Options

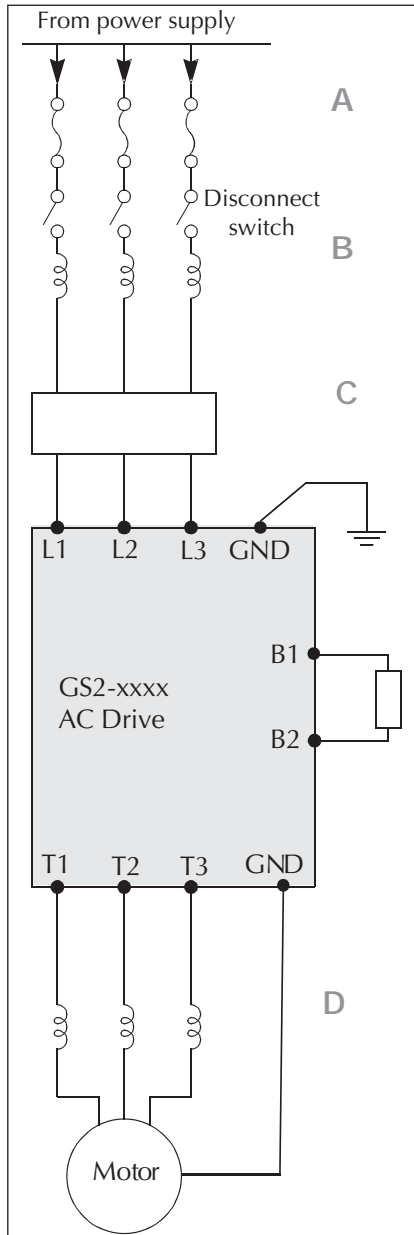

A. Input fuses

Input fuses protect the AC drive from excessive input current due to line surges, short circuits, and ground faults. They are recommended for all installations and may be required for UL-listed installations. Input fuse kits and replacement fuses are available for GS series and *DURAPULSE* AC drives.

B. Input line reactor

Input line reactors protect the AC drive from transient overvoltage conditions, typically caused by utility capacitor switching. The input line reactor also reduces the harmonics associated with AC drives. Input line reactors are recommended for all installations.

C. Input EMI filter

Input EMI filters reduce electromagnetic interference or noise on the input side of the inverter. They are required for CE compliance and recommended for installations prone to or sensitive to electromagnetic interference.

D. Output line reactor

Output line reactors protect the motor insulation against drive short circuits and IGBT reflective wave damage. Output line reactors also “smooth” the motor current waveform, allowing the motor to run cooler. The line reactor can be used for either input or output applications.

Output line reactors are recommended for operating “noninverter-duty” motors and when the length of wiring between the AC drive and motor exceeds 75 feet (10 meters for SJ300).

E. Dynamic braking

Dynamic braking allows the AC drive to produce additional braking (stopping) torque. AC drives can typically produce between 15% and 20% braking torque without the addition of any external components. The GS2, *DURAPULSE*, and SJ300 AC drives have built-in braking circuits on all units below 15 hp. These drives still require the addition of a braking resistor. Ratings larger than 15 hp require separate braking units in addition to the braking resistors.

Dynamic braking may be required for applications requiring rapid deceleration or high inertia loads.